



# CDMA

Code Division Multiple Access



# tutorialspoint

SIMPLY EASY LEARNING

[www.tutorialspoint.com](http://www.tutorialspoint.com)



<https://www.facebook.com/tutorialspointindia>



<https://twitter.com/tutorialspoint>

## About the Tutorial

---

Code Division Multiple Access (CDMA) is a channel access method normally used by 3G radio communication technology as well as in some other technologies. The technicality of CDMA technology has given significant advantages over other parallel technologies in terms of spectrum efficiency and overall performance.

This is a brief tutorial that describes all the technical terms in a simple language to make it understandable for all the interested readers.

## Audience

---

The tutorial is designed for all those readers who are planning or pursuing the CDMA course to make their career in this field. However, it is also meant for the common readers who simply want to understand — what is CDMA Technology?

## Prerequisites

---

This tutorial provides a basic overview of CDMA in a user-friendly way. We have tried to keep it simple enough so that it would be useful to any reader. A general awareness of some basics of telecommunications is sufficient to understand the concepts explained in this tutorial.

## Copyright and Disclaimer

---

© Copyright 2015 by Tutorials Point (I) Pvt. Ltd.

All the contents and graphics published in this e-book are the property of Tutorials Point (I) Pvt. Ltd. The user of this e-book can download, read, print, or keep it for his/her personal use. However, it is strictly prohibited to reuse, retain, print, copy, distribute, or republish whole or the part of this e-book in any manner for the commercial purpose without the written consent of the publisher.

We strive to produce and update the contents and tutorials of our website accurately and precisely, however, the contents may contain some inaccuracies or errors. Tutorials Point (I) Pvt. Ltd. takes no guarantee regarding the accuracy, timeliness, or completeness of our website or its contents including this tutorial. If you find any errors on our website or in this tutorial, please write us at [contact@tutorialspoint.com](mailto:contact@tutorialspoint.com).

## Table of Contents

---

About the Tutorial.....	i
Audience .....	i
Prerequisites .....	i
Copyright and Disclaimer .....	i
Table of Contents .....	ii
<b>1. CDMA – INTRODUCTION .....</b>	<b>1</b>
<b>What is CDMA? .....</b>	<b>1</b>
<b>Third Generation Standards .....</b>	<b>1</b>
<b>CDMA Development Group (CDG).....</b>	<b>2</b>
<b>IMT-2000 System .....</b>	<b>2</b>
<b>2. CDMA – CHANNELS .....</b>	<b>3</b>
<b>Forward Channel.....</b>	<b>3</b>
<b>Reverse Channel.....</b>	<b>3</b>
<b>3. CDMA – MULTIPLE ACCESS METHODS .....</b>	<b>5</b>
<b>Frequency Division Duplex .....</b>	<b>5</b>
<b>Time Division Duplex.....</b>	<b>5</b>
<b>Frequency Division Duplex .....</b>	<b>8</b>
<b>Multiple Access Methods .....</b>	<b>9</b>
<b>4. CDMA – FDMA TECHNOLOGY.....</b>	<b>10</b>
<b>FDMA Overview .....</b>	<b>10</b>
<b>Advantages of FDMA.....</b>	<b>10</b>
<b>Disadvantages of FDMA .....</b>	<b>11</b>

5.	CDMA – TDMA TECHNOLOGY.....	12
	TDMA Overview .....	12
	FDMA and TDMA .....	12
	Advantages of TDMA .....	13
	Disadvantages of TDMA .....	13
6.	CDMA – TECHNOLOGY .....	14
	CDMA Overview .....	14
	How Does CDMA Work?.....	14
	CDMA Capacity .....	15
	Centralized Methods.....	15
	Processing Gain .....	15
	Advantages of CDMA .....	16
	Disadvantages of CDMA .....	16
7.	CDMA – NETWORK.....	18
	CDMA Network Overview .....	18
	CDMA Identities .....	18
	System and Network Identity.....	19
8.	CDMA – TECHNIQUES.....	22
	Rake Receiver.....	22
	Walsh Code .....	23
9.	CDMA – SPREAD SPECTRUM .....	25
	Direct Sequence (DS).....	26
	Features of Spread Spectrum .....	28
	Advantages of Spread Spectrum .....	32
	PN Sequence .....	33

<b>Frequency Hopping Technology .....</b>	<b>33</b>
<b>10. CDMA – FADING .....</b>	<b>34</b>
<b>Multipath Fading.....</b>	<b>34</b>
<b>Fading in CDMA System .....</b>	<b>34</b>
<b>11. CDMA – NEAR-FAR PROBLEM.....</b>	<b>36</b>
<b>How Near-Far Problem Affects Communication? .....</b>	<b>36</b>
<b>12. CDMA – POWER CONTROL.....</b>	<b>37</b>
<b>Reverse Link Power Control .....</b>	<b>38</b>
<b>Forward Link Power Control.....</b>	<b>39</b>
<b>Effect of Power Control .....</b>	<b>39</b>
<b>13. CDMA – FREQUENCY ALLOCATION.....</b>	<b>40</b>
<b>14. CDMA – HANDOFF.....</b>	<b>42</b>
<b>Hard Handoff .....</b>	<b>42</b>
<b>Soft Handoff.....</b>	<b>43</b>
<b>15. CDMA – INTERFERENCES.....</b>	<b>44</b>
<b>Noise Sources.....</b>	<b>44</b>
<b>16. CDMA – Q &amp; A.....</b>	<b>46</b>

# 1. CDMA – Introduction

## What is CDMA?

---

**C**ode **D**ivision **M**ultiple **A**ccess (CDMA) is a digital cellular technology used for mobile communication. CDMA is the base on which access methods such as cdmaOne, CDMA-2000, and WCDMA are built. CDMA cellular systems are deemed superior to FDMA and TDMA, which is why CDMA plays a critical role in building efficient, robust, and secure radio communication systems.

### A Simple Analogy

Let's take a simple analogy to understand the concept of CDMA. Assume we have a few students gathered in a classroom who would like to talk to each other simultaneously. Nothing would be audible if everyone starts speaking at the same time. Either they must take turns to speak or use different languages to communicate.

The second option is quite similar to CDMA — students speaking the same language can understand each other, while other languages are perceived as noise and rejected. Similarly, in radio CDMA, each group of users is given a shared code. Many codes occupy the same channel, but only those users associated with a particular code can communicate.

### Salient Features of CDMA

CDMA, which is based on the spread spectrum technique has following salient features:

- In CDMA, every channel uses the full available spectrum.
- Individual conversations are encoded with a pseudo-random digital sequence and then transmitted using a wide frequency range.
- CDMA consistently provides better capacity for voice and data communications, allowing more subscribers to connect at any given time.
- CDMA is the common platform on which 3G technologies are built. For 3G, CDMA uses 1x EV-DO and EV-DV.

### Third Generation Standards

---

CDMA2000 uses Frequency Division Duplexing-Multicarrier (FDD-MC) mode. Here, multicarrier implies  $N \times 1.25$  MHz channels overlaid on  $N$  existing IS-95 carriers or deployed on unoccupied spectrum. CDMA2000 includes:

- 1x —uses a spreading rate of 1.2288 Mcps.
- 3x —uses a spreading rate of  $3 \times 1.2288$  Mcps or 3.6864 Mcps.
- 1xEV-DO (1x Evolution – Data Optimized)—uses a spreading rate of 1.2288 Mcps, optimized for the data.
- WCDMA/FDD-DS — Wideband CDMA (WCDMA) Frequency Division Duplexing-Direct Sequence spreading (FDD-DS) mode. This has a single 5 MHz channel.

WCDMA uses a single carrier per channel and employs a spreading rate of 3.84 Mcps.

## CDMA Development Group (CDG)

The CDMA Development Group (CDG), founded in December 1993, is an international consortium of companies. It works together to lead the growth and evolution of advanced wireless telecommunication systems.

CDG is comprised of service providers, infrastructure manufacturers, device vendors, test equipment vendors, application developers, and content providers. Its members jointly define the technical requirements for the development of complementary systems CDMA2000 and 4G. Further, the interoperability with other emerging wireless technologies are meant to increase the availability of wireless products and services to consumers and businesses worldwide.

## IMT-2000 System

	<b>IMT-DS</b> (Direct Sequence)	<b>IMT-MC</b> (Multi Carrier)	<b>IMT-TC</b> (Time Code)	<b>IMT-SC</b> (Single Carrier)	<b>IMT-FT</b> (Frequency Time)
<b>Popular name</b>	W-CDMA	CDMA2000	UTRA-TDD TD-CDMA TD-SCDMA	UWC-136	DECT
<b>Access method</b>	CDMA-FDD	CDMA-FDD	CDMA-TDD	TDMA-FDD	TDMA-TDD
<b>Organization Partners</b>	ARIB/TTC CWTS ESTI T1 TTA	ARIB/TTC CWTS TIA TTA	CWTS ESTI T1 TTA	TIA	ESTI
<b>Body of Technical Spec production</b>	3GPP(FDD)	3GPP2	3GPP(TDD) CWTS	IS-136	DECT

Approved in 2000 as ITU-R M.1457

# 2. CDMA – Channels

CDMA channels can be broadly categorized as Forward channel and Reverse channel. This chapter explains the functionalities of these channels.

## Forward Channel

---

The Forward channel is the direction of the communication or mobile-to-cell downlink path. It includes the following channels:

### I. Pilot Channel

Pilot channel is a reference channel. It uses the mobile station to acquire the time and as a phase reference for coherent demodulation. It is continuously transmitted by each base station on each active CDMA frequency. And, each mobile station tracks this signal continuously.

### II. Sync Channel

Synchronization channel carries a single, repeating message, which gives the information about the time and system configuration to the mobile station. Likewise, the mobile station can have the exact system time by the means of synchronizing to the short code.

### III. Paging Channel

Paging Channel's main objective is to send out pages, that is, notifications of incoming calls, to the mobile stations. The base station uses these pages to transmit system overhead information and mobile station specific messages.

### IV. Forward Traffic Channel

Forward Traffic Channels are code channels. It is used to assign calls, usually voice and signaling traffic to the individual users.

## Reverse Channel

---

The Reverse channel is the mobile-to-cell direction of communication or the uplink path. It consists of the following channels:

### I. Access Channel

Access channel is used by mobile stations to establish a communication with the base station or to answer Paging Channel messages. The access channel is used for short signaling message exchanges such as call-ups, responses to pages and registrations.



## II. Reverse Traffic Channel

Reverse traffic channel is used by the individual users in their actual calls to transmit traffic from a single mobile station to one or more base stations.

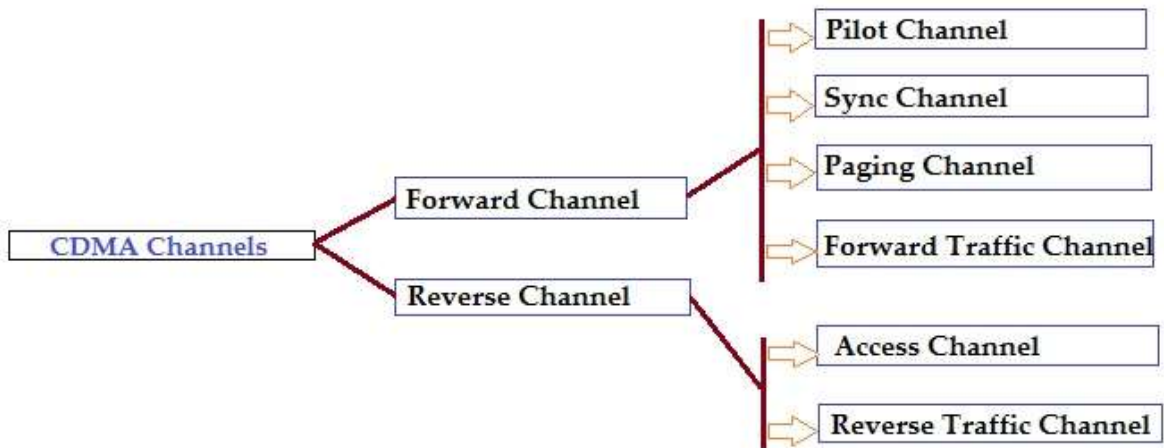

**Figure: CDMA Channels**

# 3. CDMA – Multiple Access Methods

The possibility to operate in either FDD or TDD mode is allowed for efficient use of available spectrum according to frequency allocation in different regions.

## Frequency Division Duplex

---

A duplex method whereby the Uplink and the Downlink transmissions use two separate frequency bands:

- **Uplink:** 1920 MHz to 1980 MHz
- **Downlink:** 2110 MHz to 2170 MHz
- **Bandwidth:** Each carrier is located on the center of a 5 MHz wide band

## Channel Separation

Nominal value of 5 MHz that can be adjusted.

## Channel Raster

200 kHz (center frequency must be a multiple of 200 kHz).

## Tx-Rx Frequency Separation

Nominal value of 190 MHz. This value can be either fixed or variable (minimum of 134.8 and maximum of 245.2 MHz).

## Channel Number

The carrier frequency is designated by the UTRA Absolute Radio Frequency Channel Number (UARFCN). This number is sent by the network (for the uplink and downlink) on the BCCH logical channel and is defined by  $N_u = 5 * (\text{Frequency uplink MHz})$  and  $N_D = 5 * (\text{Frequency downlink MHz})$ .

## Time Division Duplex

---

Time division duplex is a technique by which the Uplink and the Downlink transmissions are carried over the same frequency by using synchronized time intervals. The carrier uses a 5 MHz band, although there is a low chip rate solution under study by the 3GPP (1.28 Mcps). The available frequency bands for TDD will be 1900–1920 MHz and 2010–2025 MHz.

## Duplex Methods of Radio Links

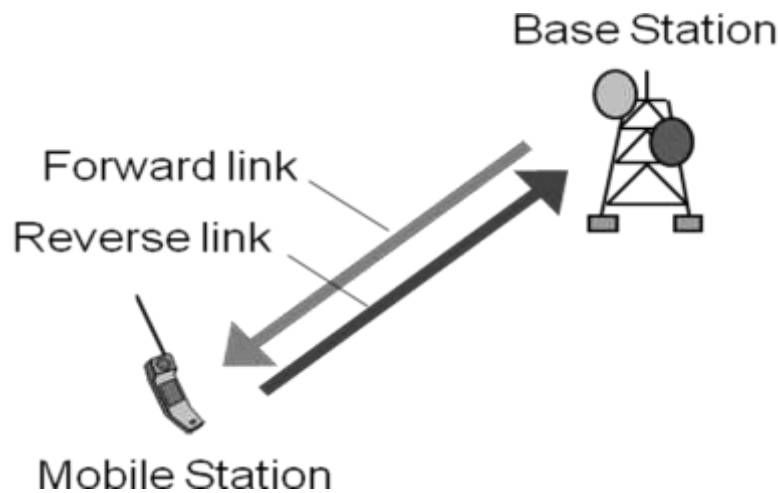

In case of Time Division Duplex, the forward link frequency is same as the reverse link frequency. In each link, signals are transmitted continuously in turns — just like a ping-pong game.

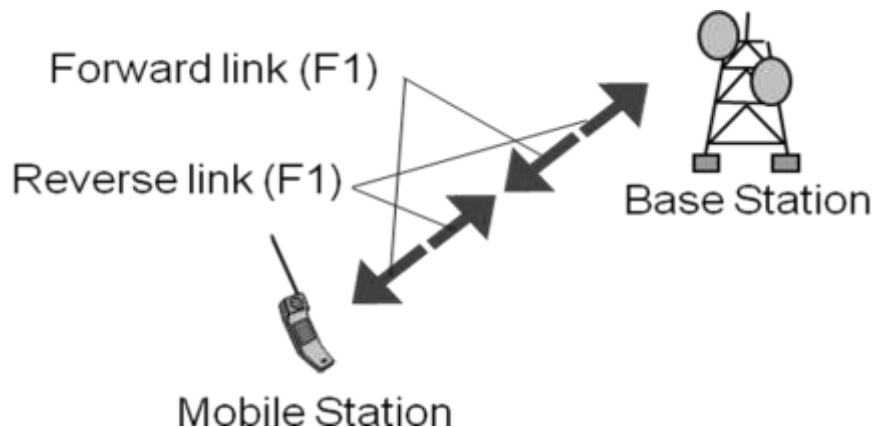

### Example of TDD System

TDD uses a single frequency band for both to transmit and to receive. Further, it shares the band by assigning alternate timeslots for transmitting and receiving operations. The information to be transmitted can be voice, video, or computer data in bit-serial format. Each time interval can be 1 byte long or may be a part of several bytes.

TDD alternates the transmission and reception station data over time. Timeslots can be of variable length. Due to the nature of high-speed data, the communicating parties cannot mean that the transmissions are intermittent. Transmissions that appear as simultaneous are actually competing each other. Digitally converted into analog voice, no one can say that it is not a full duplex.

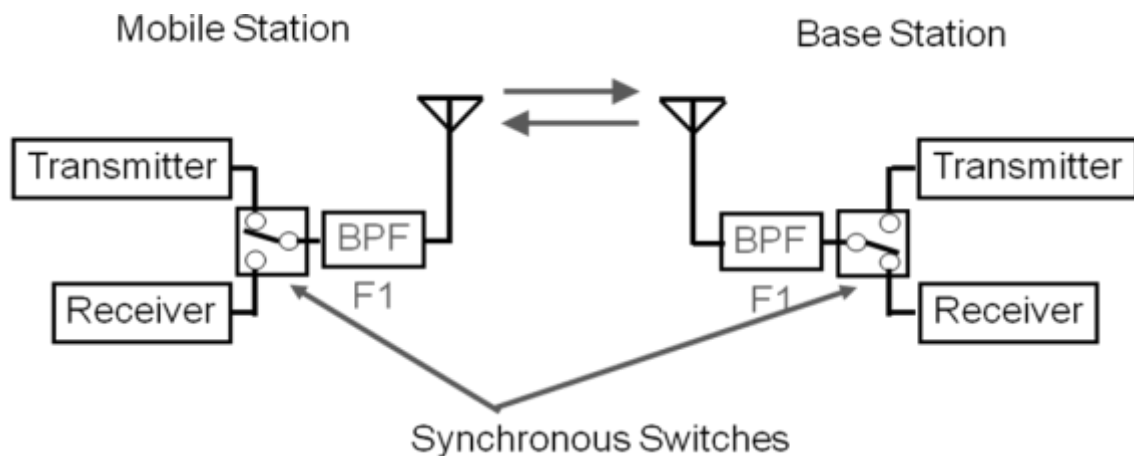

In some TDD systems, alternative time intervals are of same duration or having both DL and UL; however, the system does not need to be symmetric 50/50. The system may be asymmetrical as required.

For example, while accessing the Internet, the download speed is usually higher than the upload speed. Most of the equipment work on asynchronous mode where the download speed is higher than the upload speed. When the download speed is higher than the upload speed, less timeslots are needed for uploading. Some TDD formats offer dynamic bandwidth allocation when the number of time intervals or durations is changed on the fly as needed.

The real advantage of TDD is that it is only a single channel of the frequency spectrum and it doesn't require band guards or channel separations as the intervals take place using timeslots. The disadvantage is that the successful implementation of TDD requires a timing system. The precise timing to both the transmitter and the receiver is needed to ensure that the time intervals do not overlap or interfere with another.

Timing is often synchronized to GPS atomic clock standards specific derivative. The guard time is also needed between timeslots to avoid duplication. This time is generally equal to the transmission-reception processing time (transmission-reception switching time) and the transmission delays (latency) on the communications channel.

## Frequency Division Duplex

In Frequency Division Duplex (FDD), the forward link frequency is not the same as the reverse link frequency. In each link, signals are continuously transmitted in parallel.

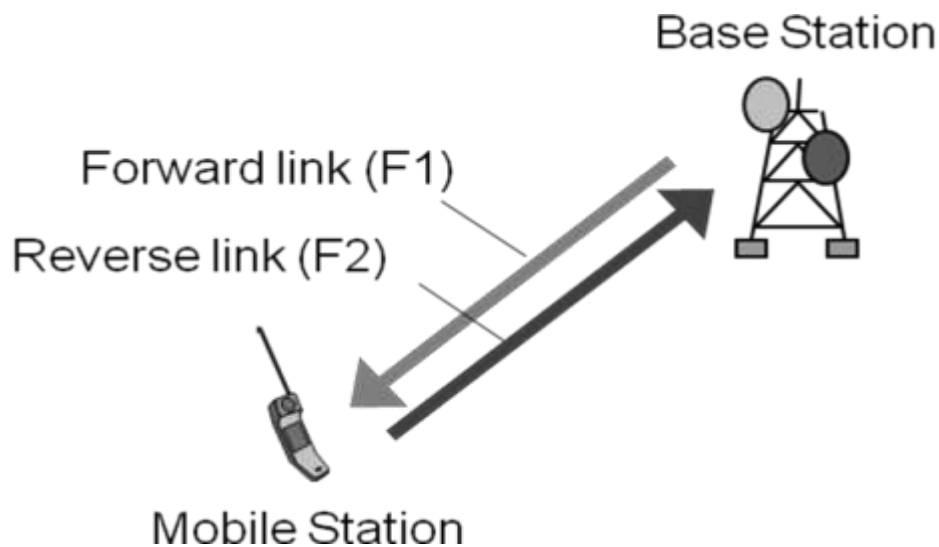

### Example of FDD System

FDD requires two symmetrical segments of spectrum for the uplink and downlink channels.

In a cell phone with a transmitter and receiver, operating simultaneously in such close proximity, the receiver has to filter as much of the signal from the transmitter as possible. More separation of the spectrum, the most effective filters.

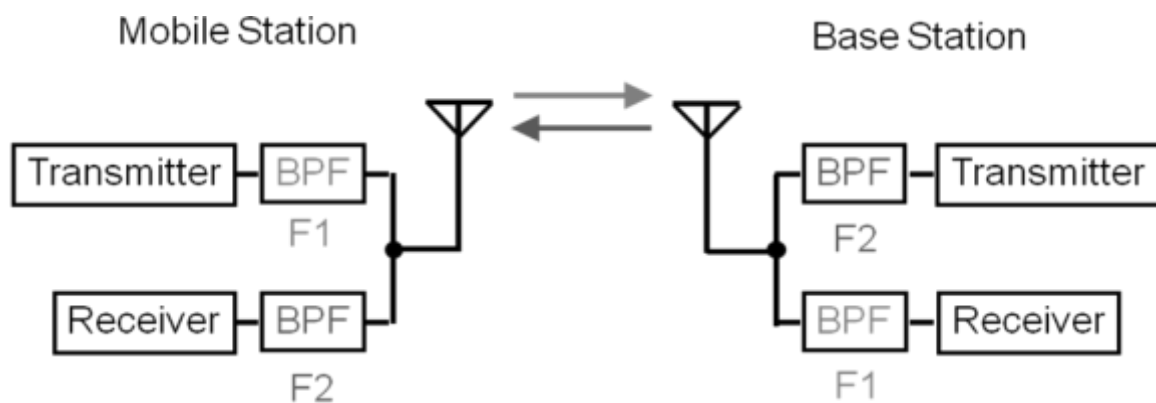

BPF: Band Pass Filter

FDD uses a lot of frequency spectrum, generally twice of the required TDD spectrum. In addition, there must be adequate spectrum separation between transmission and

reception of the channels. These bands keep saying — it cannot be used, they are unnecessary. Given the scarcity and cost of the spectrum, they are real disadvantages.

### Use of FDD

FDD is widely used in different cellular telephone systems. In some systems, the band 869-894 MHz is used as the downlink (DL) spectrum from the cell site tower to the device. And, the band 824-849 MHz is used as the uplink (UL) spectrum of the handset at the cell site.

FDD also works on a cable where transmit and receive channels are given different parts of the cable spectrum, as in cable TV systems. And, filters are used to keep the channels separate.

### Disadvantage of FDD

The drawback of FDD is that it does not allow special techniques like multiple antennas, multiple input-output (MIMO), and beamforming. These technologies are an essential element of the new strategies Long Term Evolution (LTE) 4G cell phone to increase the data rate. It is difficult to make broad enough bandwidth to cover both sets of antenna spectrum. Circuit complex dynamic adjustment is required.

## Multiple Access Methods

---

The radio channel is a communication medium shared by several users in a geographic area. Mobile stations are in competition with one another for the frequency resource to transmit their information flow. Without other measures to control concurrent access of several users, collisions can occur. Since collisions are undesirable for connection-oriented communication such as mobile phones, personal/mobile subscriber stations need to be allocated the dedicated channels on request.

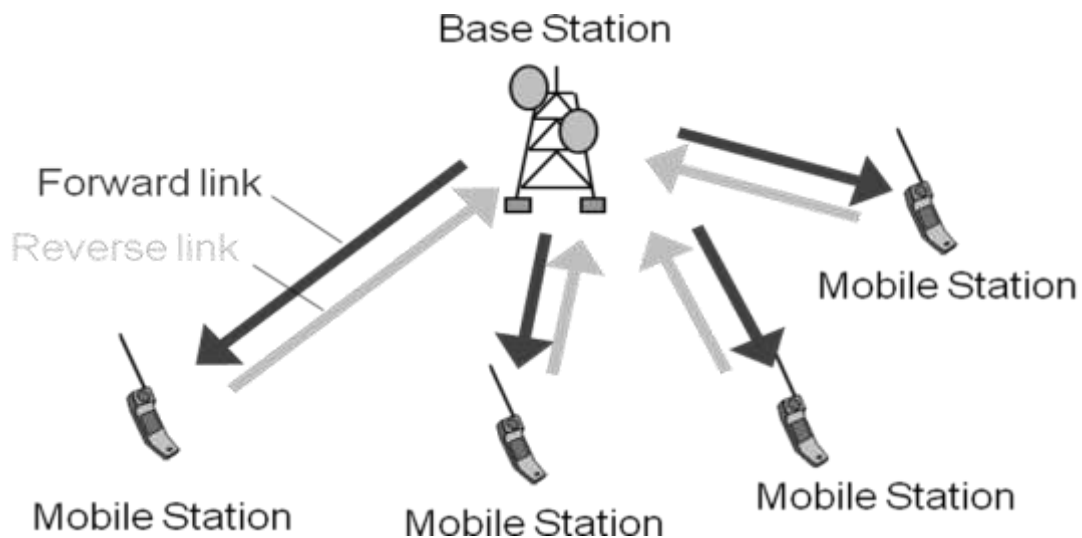

The mobile communication, sharing wireless resources on all users, must be communicated to identify the user. While identifying the user, it is referred to as "multiple access" (Multiple Access) that is receiving a radio wave of a number of transmitting stations in a receiving station (as shown in the following image).

# 4. CDMA – FDMA Technology

Frequency Division Multiple Access (FDMA) is one of the most common analogue multiple access methods. The frequency band is divided into channels of equal bandwidth so that each conversation is carried on a different frequency (as shown in the figure below).

## FDMA Overview

In FDMA method, guard bands are used between the adjacent signal spectra to minimize crosstalk between the channels. A specific frequency band is given to one person, and it will be received by identifying each of the frequencies on the receiving end. It is often used in the first generation of analog mobile phone.

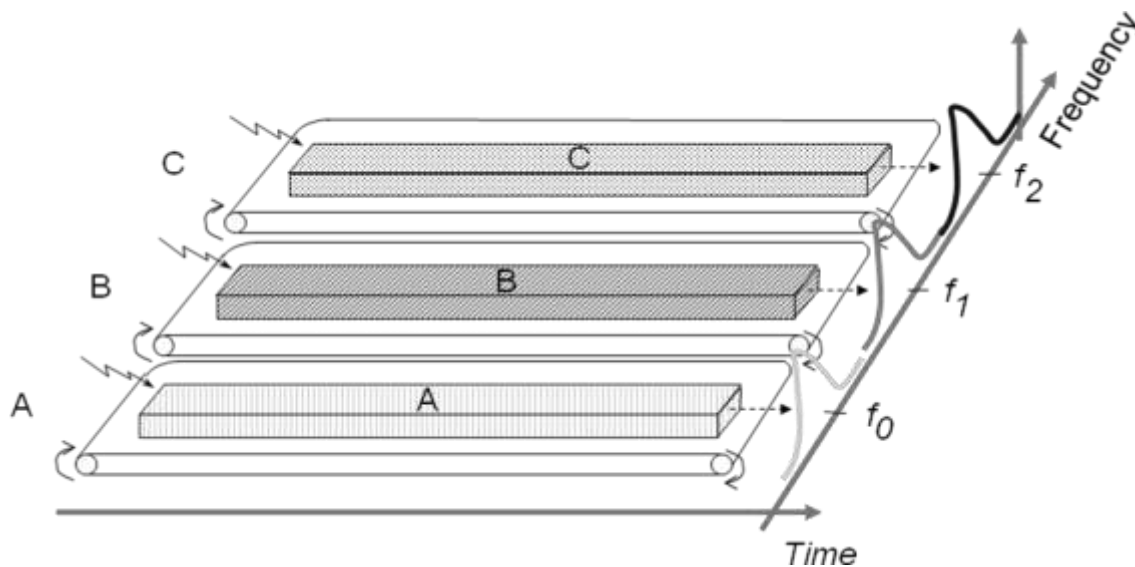

## Advantages of FDMA

As FDMA systems use low bit rates (large symbol time) compared to average delay spread, it offers the following advantages:

- Reduces the bit rate information and the use of efficient numerical codes increases the capacity.
- It reduces the cost and lowers the inter symbol interference (ISI).
- Equalization is not necessary.
- An FDMA system can be easily implemented. A system can be configured so that the improvements in terms of speech encoder and bit rate reduction may be easily incorporated.
- Since the transmission is continuous, less number of bits are required for synchronization and framing.

## Disadvantages of FDMA

---

Although FDMA offers several advantages, it has a few drawbacks as well, which are listed below:

- It does not differ significantly from analog systems; improving the capacity depends on the signal-to-interference reduction, or a signal-to-noise ratio (SNR).
- The maximum flow rate per channel is fixed and small.
- Guard bands lead to a waste of capacity.
- Hardware implies narrowband filters, which cannot be realized in VLSI and therefore increases the cost.



# 5. CDMA – TDMA Technology

Time Division Multiple Access (TDMA) is a digital cellular telephone communication technology. It facilitates many users to share the same frequency without interference. Its technology divides a signal into different timeslots, and increases the data carrying capacity.

## TDMA Overview

Time Division Multiple Access (TDMA) is a complex technology, because it requires an accurate synchronization between the transmitter and the receiver. TDMA is used in digital mobile radio systems. The individual mobile stations cyclically assign a frequency for the exclusive use of a time interval.

In most of the cases, the entire system bandwidth for an interval of time is not assigned to a station. However, the frequency of the system is divided into sub-bands, and TDMA is used for the multiple access in each sub-band. Sub-bands are known as **carrier frequencies**. The mobile system that uses this technique is referred as the **multi-carrier systems**.

In the following example, the frequency band has been shared by three users. Each user is assigned definite **timeslots** to send and receive data. In this example, user 'B' sends after user 'A,' and user 'C' sends thereafter. In this way, the peak power becomes a problem and larger by the burst communication.

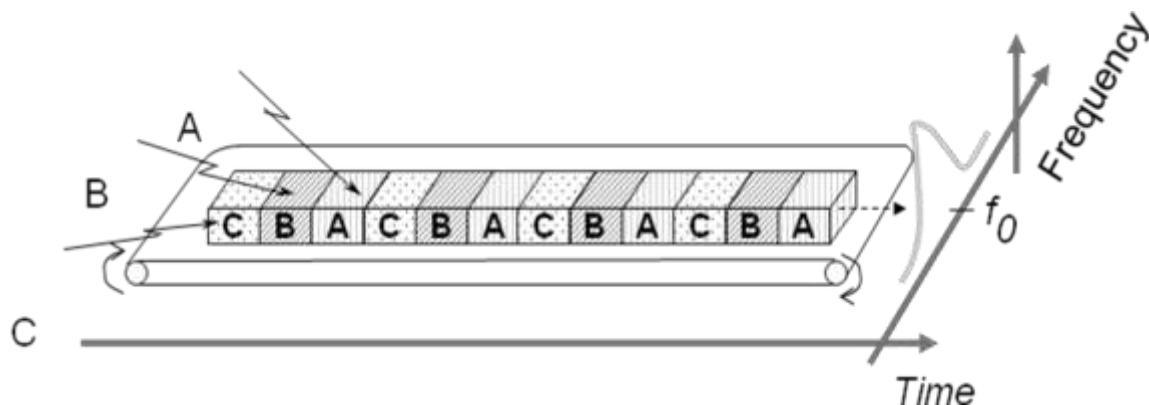

## FDMA and TDMA

This is a multi-carrier TDMA system. A 25 MHz frequency range holds 124 single channels (carrier frequencies 200) bandwidth of each kHz; each of these frequency channels contains 8 TDMA conversation channels. Thus, the sequence of timeslots and frequencies assigned to a mobile station is the physical channels of a TDMA system. In each timeslot, the mobile station transmits a data packet.

The period of time assigned to a timeslot for a mobile station also determines the number of TDMA channels on a carrier frequency. The period of timeslots are combined in a so-called TDMA frame. TDMA signal transmitted on a carrier frequency usually

requires more bandwidth than FDMA signal. Due to the use of multiple times, the gross data rate should be even higher.

## **Advantages of TDMA**

---

Here is a list of few notable advantages of TDMA:

- Permits flexible rates (i.e. several slots can be assigned to a user, for example, each time interval translates 32Kbps, a user is assigned two 64 Kbps slots per frame).
- Can withstand gusty or variable bit rate traffic. Number of slots allocated to a user can be changed frame by frame (for example, two slots in the frame 1, three slots in the frame 2, one slot in the frame 3, frame 0 of the notches 4, etc.).
- No guard band required for the wideband system.
- No narrowband filter required for the wideband system.

## **Disadvantages of TDMA**

---

The disadvantages of TDMA are as follow:

- High data rates of broadband systems require complex equalization.
- Due to the burst mode, a large number of additional bits are required for synchronization and supervision.
- Call time is needed in each slot to accommodate time to inaccuracies (due to clock instability).
- Electronics operating at high bit rates increase energy consumption.
- Complex signal processing is required to synchronize within short slots.

# 6. CDMA – Technology

Code Division Multiple Access (CDMA) is a sort of multiplexing that facilitates various signals to occupy a single transmission channel. It optimizes the use of available bandwidth. The technology is commonly used in ultra-high-frequency (UHF) cellular telephone systems, bands ranging between the 800-MHz and 1.9-GHz.

## CDMA Overview

---

Code Division Multiple Access system is very different from time and frequency multiplexing. In this system, a user has access to the whole bandwidth for the entire duration. The basic principle is that different CDMA codes are used to distinguish among the different users.

Techniques generally used are direct sequence spread spectrum modulation (DS-SS), frequency hopping or mixed CDMA detection (JCDMA). Here, a signal is generated which extends over a wide bandwidth. A code called **spreading code** is used to perform this action. Using a group of codes, which are orthogonal to each other, it is possible to select a signal with a given code in the presence of many other signals with different orthogonal codes.

## How Does CDMA Work?

---

CDMA allows up to 61 concurrent users in a 1.2288 MHz channel by processing each voice packet with two PN codes. There are 64 Walsh codes available to differentiate between calls and theoretical limits. Operational limits and quality issues will reduce the maximum number of calls somewhat lower than this value.

In fact, many different "signals" baseband with different spreading codes can be modulated on the same carrier to allow many different users to be supported. Using different orthogonal codes, interference between the signals is minimal. Conversely, when signals are received from several mobile stations, the base station is capable of isolating each as they have different orthogonal spreading codes.

The following figure shows the technicality of the CDMA system. During the propagation, we mixed the signals of all users, but by that you use the same code as the code that was used at the time of sending the receiving side. You can take out only the signal of each user.

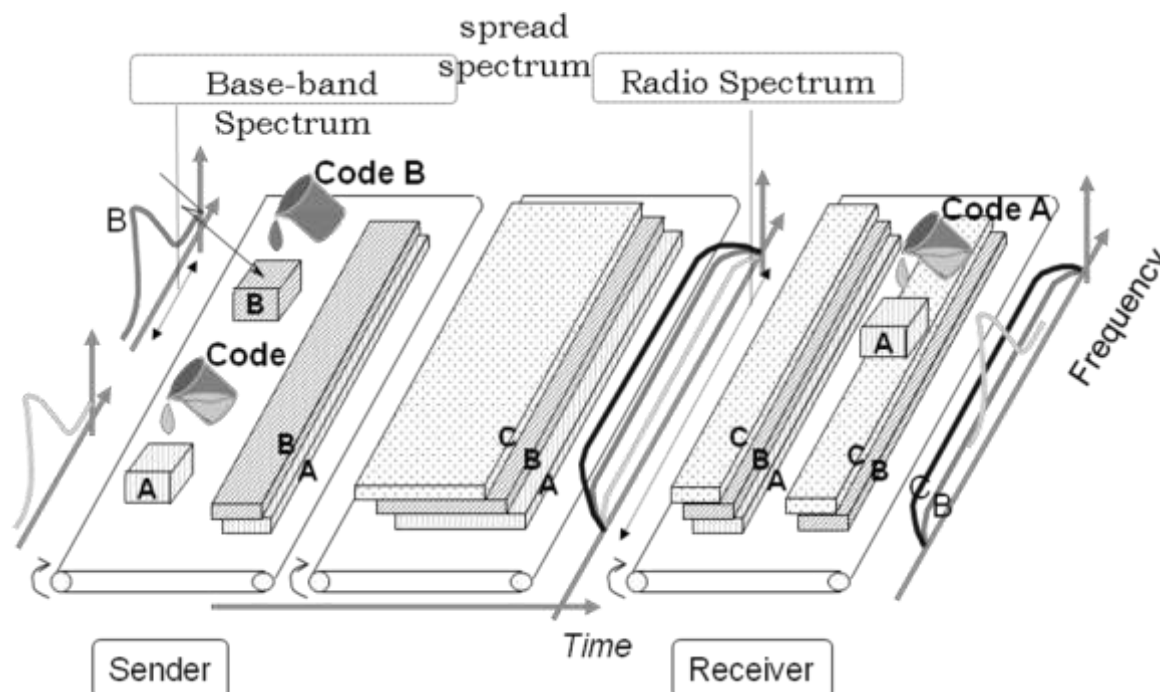

## CDMA Capacity

The factors deciding the CDMA capacity are:

- Processing Gain
- Signal to Noise Ratio
- Voice Activity Factor
- Frequency Reuse Efficiency

Capacity in CDMA is soft, CDMA has all users on each frequency and users are separated by code. This means, CDMA operates in the presence of noise and interference.

In addition, neighboring cells use the same frequencies, which means no re-use. So, CDMA capacity calculations should be very simple. No code channel in a cell, multiplied by no cell. But it is not that simple. Although not available code channels are 64, it may not be possible to use a single time, since the CDMA frequency is the same.

## Centralized Methods

- The band used in CDMA is 824 MHz to 894 MHz (50 MHz + 20 MHz separation).
- Frequency channel is divided into code channels.
- 1.25 MHz of FDMA channel is divided into 64 code channels.

## Processing Gain

CDMA is a spread spectrum technique. Each data bit is spread by a code sequence. This means, energy per bit is also increased. This means that we get a gain of this.

$$P \text{ (gain)} = 10 \log (W/R)$$

**W is Spread Rate**

**R is Data Rate**

$$\text{For CDMA } P \text{ (gain)} = 10 \log (1228800/9600) = 21\text{dB}$$

This is a gain factor and the actual data propagation rate. On an average, a typical transmission condition requires a signal to the noise ratio of 7 dB for the adequate quality of voice.

Translated into a ratio, signal must be five times stronger than noise.

$$\begin{aligned} \text{Actual processing gain} &= P \text{ (gain)} - \text{SNR} \\ &= 21 - 7 = 14\text{dB} \end{aligned}$$

CDMA uses variable rate coder

**The Voice Activity Factor of 0.4 is considered = -4dB.**

Hence, CDMA has 100% frequency reuse. Use of same frequency in surrounding cells causes some additional interference.

**In CDMA frequency, reuse efficiency is 0.67 (70% eff.) = -1.73dB**

## Advantages of CDMA

---

CDMA has a soft capacity. The greater the number of codes, the more the number of users. It has the following advantages:

- CDMA requires a tight power control, as it suffers from near-far effect. In other words, a user near the base station transmitting with the same power will drown the signal latter. All signals must have more or less equal power at the receiver.
- Rake receivers can be used to improve signal reception. Delayed versions of time (a chip or later) of the signal (multipath signals) can be collected and used to make decisions at the bit level.
- Flexible transfer may be used. Mobile base stations can switch without changing operator. Two base stations receive mobile signal and the mobile receives signals from the two base stations.
- Transmission Burst - reduces interference.

## Disadvantages of CDMA

---

The disadvantages of using CDMA are as follows:

- The code length must be carefully selected. A large code length can induce delay or may cause interference.
- Time synchronization is required.
- Gradual transfer increases the use of radio resources and may reduce capacity.

- As the sum of the power received and transmitted from a base station needs constant tight power control. This can result in several handovers.

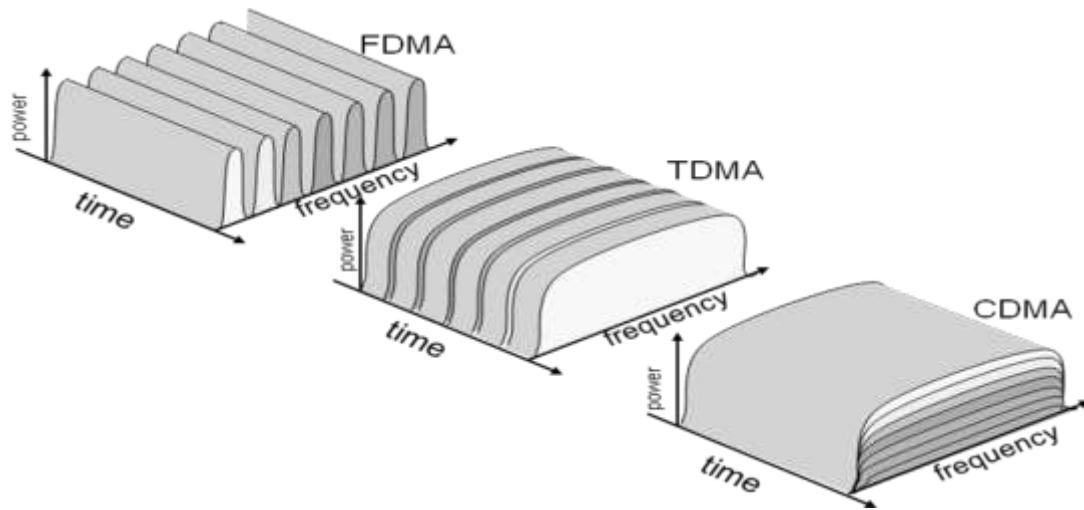

# 7. CDMA – Network

CDMA Network is the system meant to regulate CDMA technology. It includes all aspects and functionality starting from the base station, transmitting antenna, receiving antenna, to mobile switching centers.

## CDMA Network Overview

---

A base station is an essential element of the CDMA network. A base station covers a small geographical area called a **cell**. A cell may be omnidirectional or sectoral. Each base station has a transmitting antenna and two receiving antennas for each cell. Two receiving antennas are used per cell for the purpose of **spatial diversity**. In many applications, it is a BSC (Base Station Controller), which controls several base stations.

As the rate of the mobile phone data is either 13kbps or 8kbps, which is non-ISDN, but the switches which are the mobile switching center (MSC) are generally switched to 64 kbps. Therefore, before it is switched, it is necessary to convert this mobile data rates to 64 kbps. This is accomplished by a member, which is the **transcoder**. The transcoder may be a separate element or it can be collocated in each base station or MSC.

All base stations are connected to the MSC, which is the **mobile switching center**. MSC is the entity that manages the establishment, connection, maintenance, and disposal of calls within the network and also with the outside world. MSC also has a database called HLR/AC, which is a home location register/authentication center. HLR is the database, which maintains the database of all network subscribers. AC Authentication Centre is the part of the security of the HLR, which some algorithms to examine mobile phones.

The MSC is connected to the outside world, i.e. the fixed line network. MSC can also be connected to several other MSCs.

## CDMA Identities

---

Network Identities:-

- SID (System Identity)
- NID (Network Identity)

Mobile Station Identities:-

- ESN (Electronic Serial Number)
- Permuted ESN
- IMSI (International Mobile Station Identity)
- IMSI\_S
- IMSI\_11\_12
- Station Class Mark

## System and Network Identity

A base station is a member of a cellular system and a network. A network is a subset of a system. The systems are installed with an identification called **Identification System (CIS)**. The networks with a system receiving is **Network identification (NID)**. It is a uniquely identified network pair of (SID, NID). The mobile station has a list of one or more home (non-roaming) pairs (SID, NID).

### SID

A system identification indicator 15 bits (SID) is stored in a mobile station. It is used to determine the host system of the mobile stations. The bit allocation of the system identification indicator is shown below.

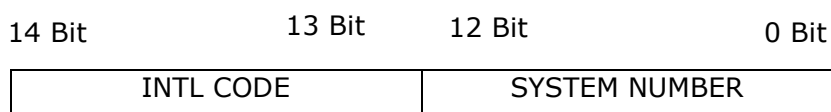

The distribution of international codes (INTL) (bits 14 and 13) is also shown in the table. Bits 12-0 is assigned to each US system by the FCC for non-US countries. The bit allocation will be made by local regulatory authorities.

### NID

NID has a range of 0-65535 reserved values. Value of 65535 in a SID means, NID pair is to indicate that the Mobile Station considers the entire SID as home.

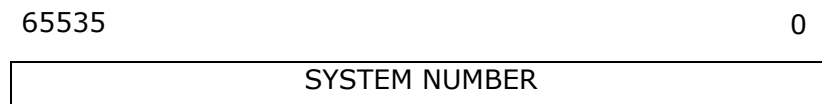

## Systems and Networks

A mobile station has a list of one or more home (non-roaming) pairs (SID, NID). A mobile station is roaming when the base station broadcast (SID, NID) pair does not match with one of the non-roaming mobile stations (SID, NID) pairs.

A mobile station is a foreign NID roamer:

- if the mobile station is roaming and there are some (SID, NID) pair in the mobile stations (SID, NID) list that corresponds to SID.
- if the mobile station is roaming and there are some (SID, NID) pair in the mobile stations (SID, NID) list for which no matching SID is available (means a mobile station has roaming customer foreign SID).

## Electronic Serial Number (ESN)

ESN is a 32-bit binary number that uniquely identifies the mobile station in a CDMA cellular system. It should be set at the factory and cannot be easily changed in the field. Changing the ESN will require special equipment, not normally available to subscribers. The bit allocation of ESN is shown below:



31 Bit	24 Bit	23 Bit	17 Bit	18 Bit	0 Bit
MFR CODE		RESERVED VALUE		SERIAL NUMBER	

The circuit that provides the ESN must be isolated so that no one can contact and tamper. Attempts to change the ESN circuit should make the mobile station inoperative. At the time of the issuance of the initial acceptance, the manufacturer must be assigned a code Manufacturers (MFR) in the eight most significant bits (bits 31-24 bits) 32-bit serial number. Bits 23-18 are reserved (initially zero). And, every manufacturer only allocates 17 bits to 0. When a manufacturer has used almost all possible combinations of serial numbers in bits 17-0, the manufacturer may submit a notification to the FCC. The FCC will assign the next sequential binary number in the reserve block (bits 23 through).

### Permuted ESN

CDMA is a spread spectrum technique where multiple users to access the system at the same example in a cell, and of course on the same frequency. Therefore, it discriminates the users on the reverse link (i.e. information from MS to the base station). It spreads information using codes that are unique to the mobile station in all the CDMA cellular systems. This code has an element that is the ESN, but it doesn't use the ESN in the same format instead, it uses an ESN swapped.

If there are two mobiles in a cell of the same brand and have consecutive serial numbers and for the receiver of the base station, it becomes difficult to connect them. Therefore, to avoid a strong correlation between the long codes corresponding to successive ESN, we use permuted ESNs.

### International Mobile Station Identity (IMSI)

Mobile stations are identified by the identity of the international mobile station Identity (IMSI). The IMSI consists of up to 10 to 15 numeric digits. The first three digits of the IMSI are the country code of the mobile (MCC), the remaining digits are the National NMSI mobile station identity. The NMSI consists of the mobile network code (MNC) and the mobile station identification number (SIDS).

MCC	MSN	MSIN
	<b>NMSI</b>	
<b>IMSI ≤15 digits</b>		

- MCC: Mobile Country Code
- MNC: Mobile Network Code
- MSIN: Mobile Station Identification
- NMSI: National Mobile Station Identity

An IMSI that is 15 digits in length is called a class 0 IMSI (NMSI is the 12 digits in length). IMSI, which is less than 15 digits in length, is called a class 1 IMSI (NMSI the length is less than 12 counts). For CDMA operation, the same IMSI may be registered in

multiple mobile stations. Individual systems may or may not allow these capabilities. The management of these functions is a function of the base station and the system operator.

# 8. CDMA – Techniques

## Rake Receiver

Due to the reflection on the challenges of a broadband, radio channel can consists of many copies (multipath), signals originally transmitted with different amplitude, phase, and delay. If the signal components arrive over a chip period of each other, a rake receiver may be used to adjust and combine. The Rake receiver uses a principle of diversity through multiple paths. The figure given below shows the Rake receiver scheme.

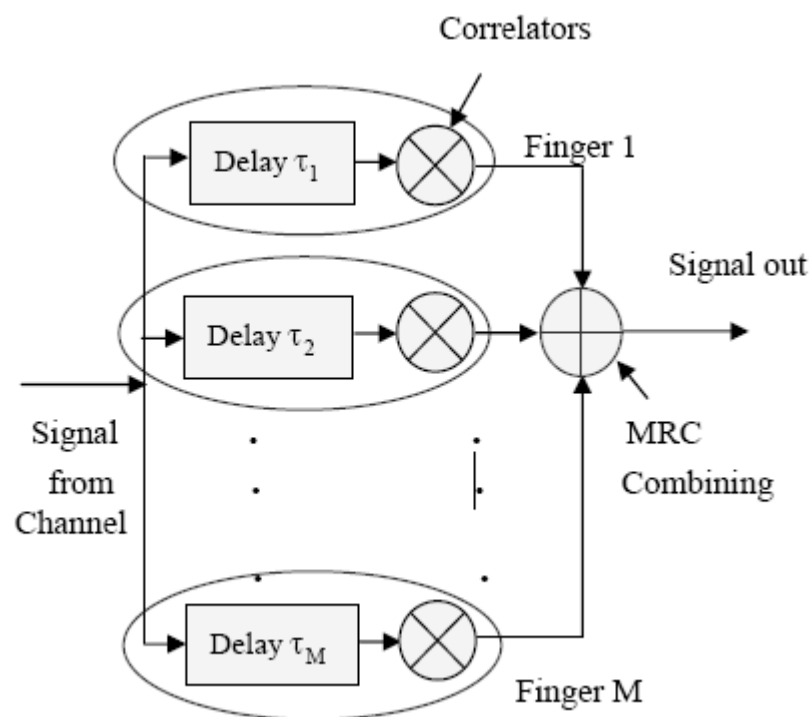

The Rake receiver processes several multipath signals components. The correlator outputs are combined to achieve better reliability and communication performance. Bit decision on the basis of a single correlation can produce a large bit error rate as multipath component processed by the fact that the correlator can be damaged by discoloration. If the output of a correlator is corrupted by fading, the other cannot be, and the corrupt signal can be reduced by the weighting process.

## Walsh Code

Walsh Codes are most commonly used in the orthogonal codes of CDMA applications. These codes correspond to lines of a special square matrix called the Hadamard matrix. For a set of Walsh codes of length  $N$ , it consists of  $n$  lines to form a square matrix of  $n \times n$  Walsh code.

The IS-95 system uses 64 Walsh function matrix 64. The first line of this matrix contains a string of all zeros with each of the following lines containing different combinations of bit 0 and 1. Each line is orthogonal and equal representation for binary bits. When implemented with the CDMA system, each mobile user uses one of the 64 sequences of rows in the matrix as a spreading code. And, it provides zero cross-correlation among all the other users. This matrix is defined recursively as follows:

$$W_1 = [0] \qquad W_{2n} = \begin{bmatrix} W_n & W_n \\ W_n & \bar{W}_n \end{bmatrix}$$

Where  $n$  is a power of 2 and indicates the different dimensions of the matrix  $W$ . Further,  $\bar{}$  represents the logic NOT operation on all bits in this matrix. The three matrices  $W_2$ ,  $W_4$ , and  $W_8$ , respectively show the Walsh function for the dimension 2, 4, and 8.

$$W_2 = \begin{bmatrix} 0 & 0 \\ 0 & 1 \end{bmatrix} \qquad W_4 = \begin{bmatrix} 0 & 0 & 0 & 0 \\ 0 & 1 & 0 & 1 \\ 0 & 0 & 1 & 1 \\ 0 & 1 & 1 & 0 \end{bmatrix} \qquad W_8 = \begin{bmatrix} 0 & 0 & 0 & 0 & 0 & 0 & 0 & 0 \\ 0 & 1 & 0 & 1 & 0 & 1 & 0 & 1 \\ 0 & 0 & 1 & 1 & 0 & 0 & 1 & 1 \\ 0 & 1 & 1 & 0 & 0 & 1 & 1 & 0 \\ 0 & 0 & 0 & 0 & 1 & 1 & 1 & 1 \\ 0 & 1 & 0 & 1 & 1 & 0 & 1 & 0 \\ 0 & 0 & 1 & 1 & 1 & 1 & 0 & 0 \\ 0 & 1 & 1 & 0 & 1 & 0 & 0 & 1 \end{bmatrix}$$

Each line of the 64 Walsh matrix 64 corresponds to a channel number. The channel number 0 is mapped to the first row of the Walsh matrix, which is the code of all zeros. This channel is also known as the pilot channel and is used to form and to estimate the impulse response of a mobile radio channel.

To calculate the cross-correlation between the sequences, we will need to convert the bits into the matrix to form the antithesis of  $\pm 1$  values. However, all users on the same CDMA channel can be synchronized with an accuracy of one chip interval using a common long PN sequence. It also functions as a data scrambler.

- Walsh Code is a group of spreading codes having good autocorrelation properties and poor cross correlation properties. Walsh codes are the backbone of CDMA systems and are used to develop the individual channels in CDMA.
- For IS-95, there are 64 codes available.
  - Code '0' is used as the pilot and code '32' is used for synchronization.
  - Codes 1 through 7 are used for control channels, and the remaining codes are available for traffic channels. Codes 2 to 7 are also available for traffic channels if they are not needed.

- For cdma2000, multitude of Walsh codes exist, which vary in length to accommodate the different data rates and Spreading Factors of the different Radio Configurations.
- One of the 64 orthogonal bit pattern at a rate of 1.2288 Mcps.
- Walsh codes are used to identify the data for each individual transmission. In the forward link, they define forward code channels within a CDMA frequency.
- In the reverse link, all 64 codes are used by each reverse channel to carry information.

Take a look at the following illustration. It shows how multiplexing is carried out using Walsh Code.

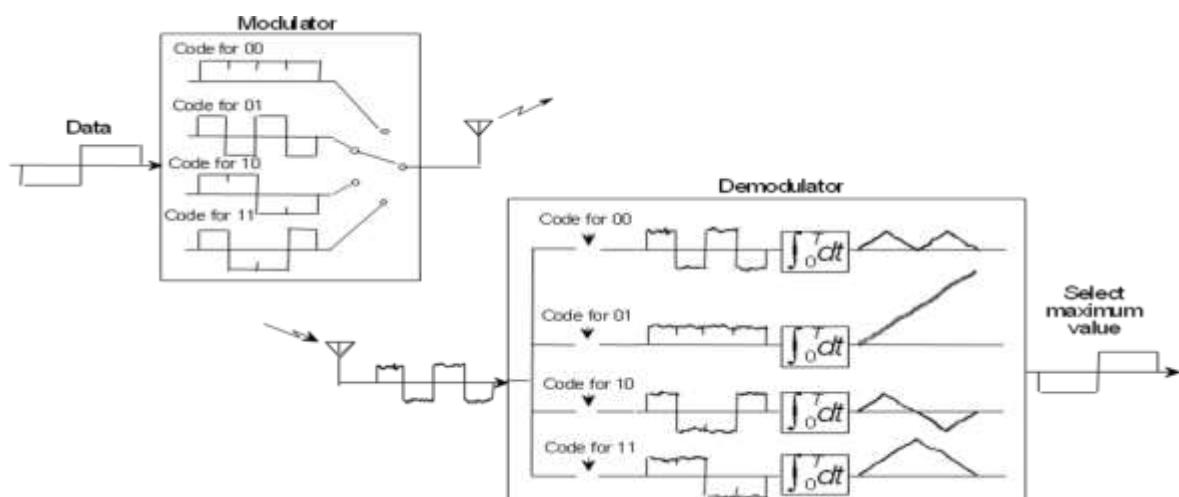

# 9. CDMA – Spread Spectrum

All technical modulation and demodulation strive for greater power and/or efficiency of bandwidth in a white Gaussian additive stationary noise channel. Since bandwidth is a limited resource, one of the primary design goals of all the modulation schemes is to minimize the bandwidth required for transmission. On the other hand, spread spectrum techniques use a transmission bandwidth that is order of the magnitude greater than the bandwidth required the minimum signal.

The advantage of spread spectrum technique is that – many users can simultaneously use the same bandwidth without interfering with each other. Therefore, spread spectrum is not economic when the number of users is less.

- Spread spectrum is a form of wireless communications in which the frequency of the transmitted signal is deliberately varied resulting higher bandwidth.
- Spread-spectrum is apparent in the Shannon and Hartley channel-capacity theorem:

$$C = B \times \log_2 (1 + S/N)$$

- In the given equation, 'C' is the channel capacity in bits per second (bps), which is the maximum data rate for a theoretical bit-error rate (BER). 'B' is the required channel bandwidth in Hz, and S/N is the signal-to-noise power ratio.
- Spread spectrum uses wideband, noise-like signals that are hard to detect, intercept, or demodulate. Additionally, spread-spectrum signals are harder to jam (interfere with) than narrow band signals.
- Since spread-spectrum signals are so wide, they transmit at a much lower spectral power density, measured in watts per hertz, than narrow band transmitters. Spread-spectrum and narrowband signals can occupy the same band, with little or no interference. This capability is the main attraction for all the interest in spread spectrum today.

## Points to Remember:

- The transmitted signal bandwidth is greater than the minimal information bandwidth, which is needed to transmit the signal successfully.
- Some function other than the information itself is normally employed to determine the resultant transmitted bandwidth.

Following are the two types of spread spectrum techniques:

1. Direct Sequence and
2. Frequency Hopping.

Direct Sequence is adopted by CDMA.

## Direct Sequence (DS)

Direct Sequence Code Division Multiple Access (DS-SS) is a technique to multiplex users by different codes. In this technique, the same bandwidth is used by different users. Each user is assigned with one its own spreading code. These sets of codes are divided into two classes:

1. Orthogonal Codes and
2. Non-Orthogonal Codes

Walsh sequences come into the first category which is Orthogonal Codes whereas other sequences i.e. PN, Gold, and Kasami are shift register sequences.

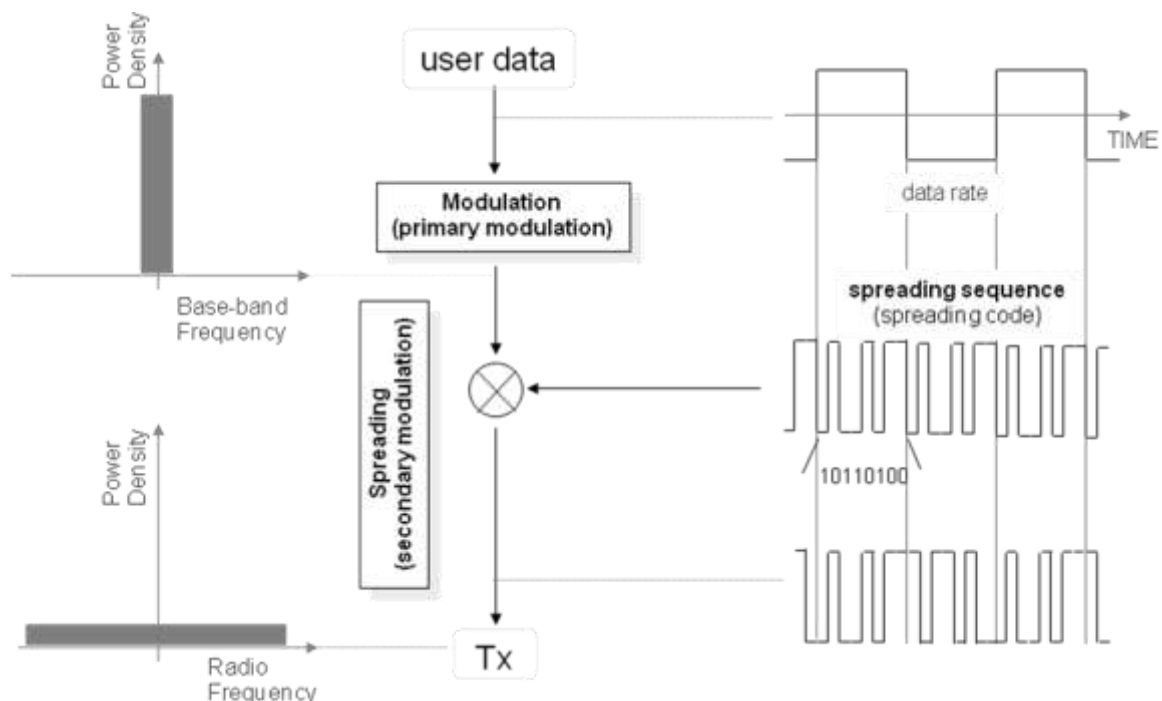

Orthogonal codes are assigned to the users, the output of the correlator in the receiver will be zero except the desired sequence. In synchronous direct sequence, the receiver receives the same code sequence which was transmitted so that there is no time shift between the users.

### Demodulating DS Signals – 1

In order to demodulate DS signals, you need to know the code that was used at the time of transmission. In this example, by multiplying the code used in the transmission to the reception signal, we can get the transmitted signal.

In this example, multiple codes were used at the time of transmission (10,110,100) to the received signal. Here, we have calculated by using the law of two additives (Modulo 2 Addition). It is further demodulated by multiplying the code that was used at the time of this transmission, called the **reverse diffusion** (de-spreading). In the diagram given below, it can be seen that during the transmission of the data to the narrow band (Narrow Band) spectrum, the spectrum of the signal is dispread.

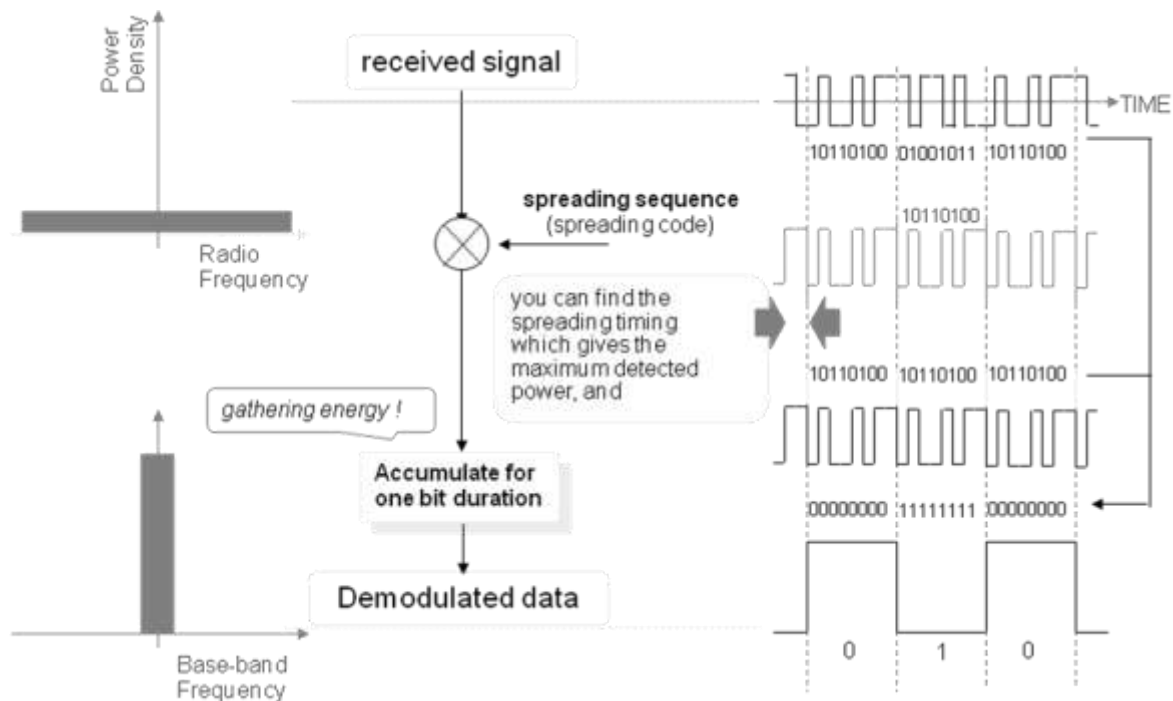

## Demodulating DS Signals – 2

On the other hand, if you do not know the code that was used at the time of transmission, you will not be able to demodulate. Here, you are trying to demodulation in the code of different (10101010) and the time of transmission, but it has failed.

Even looking at the spectrum, it is spreading during the time of transmission. When it is passed through a band-pass filter (Band Path Filter), only this small signal remains and these are not demodulated.



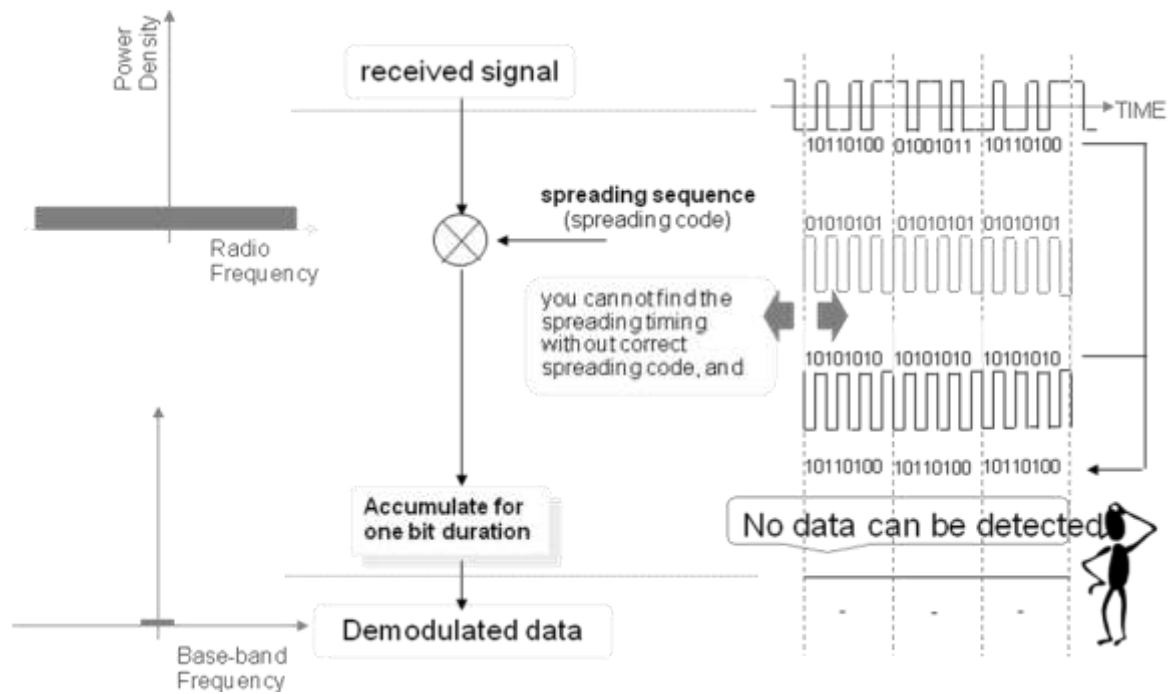

## Features of Spread Spectrum

As shown in the following figure, the power density of Spread Spectrum signals could be lower than the noise density. This is a wonderful feature that can keep the signals protected and maintain privacy.

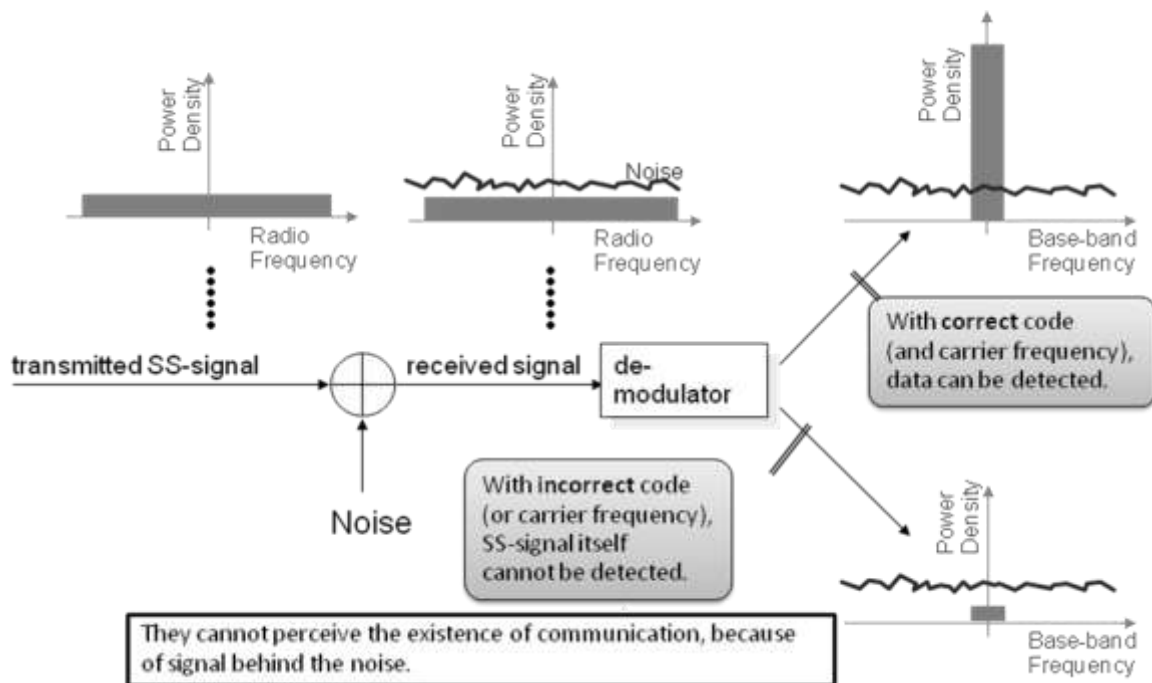

By spreading the spectrum of the transmitted signal, one can reduce its power density such that it becomes less than the power density of the noise. In this way, it is possible to hide the signal in the noise. It can be demodulated if you know the code that was used to send the signal. In case the code is not known, then the received signal will remain hidden in the noise even after the demodulation.

## DS-CDMA

DS code is used in CDMA. So far, it has been explained basic part of the spread spectrum communication. From here, we will explain how Direct Sequence Code Division Multiple Access (DS-SS) works.

The signal which is spread spectrum, can be demodulated only by a code used for transmission. By using this, the transmission signal of each user can be identified by the separate code when it receives the signal. In the given example, the spread signal of the user A at the code A, and diffused signal of user B at code B. Each of the signal when it receives are mixed. However, by the inverse diffuser (Despreader), it identifies the signal of each user.

### DS-SS System - Forward Link

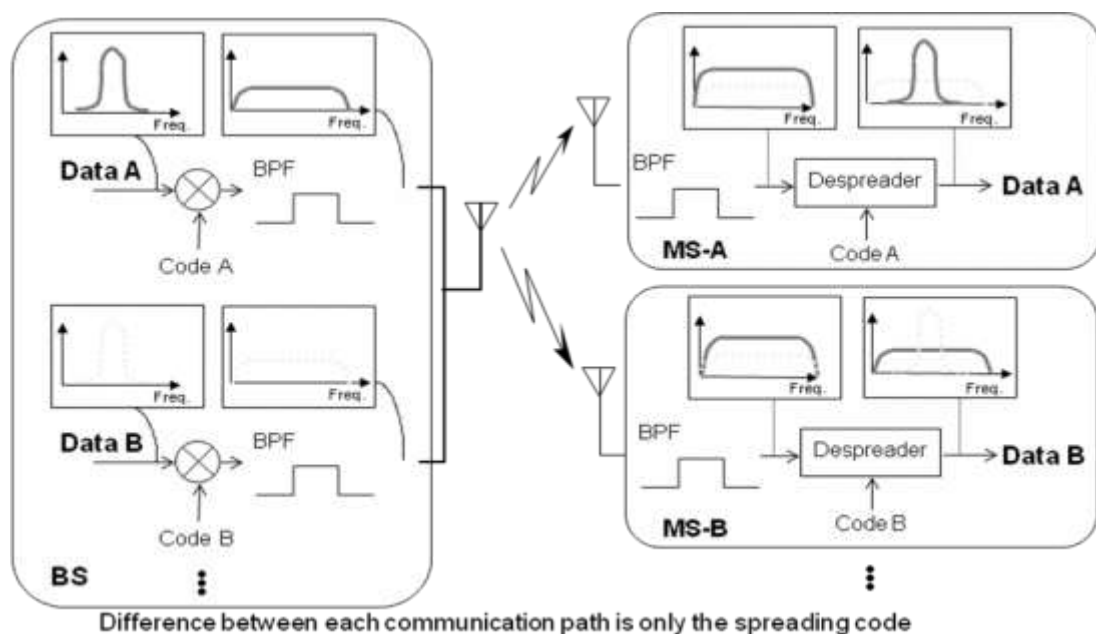

## DS-SSMA System - Reverse Link

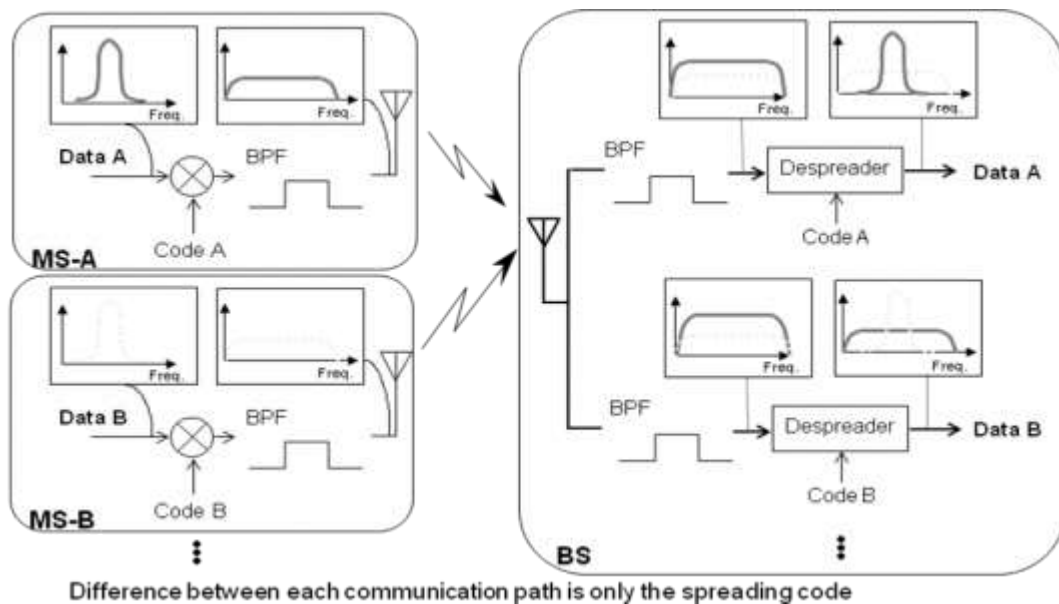

## Spreading Code

### Cross-Correlation

Correlation is a method of measurement of how precisely a given signal matches with a desired code. In CDMA technology, each user is assigned with a different code, the code which is being assigned or chosen by the user is very important to modulate the signal because it is related to the performance of the CDMA system.

One will get best performance when there will be clear separation between the signal of desired users and signals of the other users. This separation is made by correlating the desired signal code which was locally generated and other received signals. If the signal matches with the code of the user, then the correlation function will be high and the system can extract that signal. If the user's desired code has nothing in common with the signal, the correlation should be as close to zero as possible (thus eliminating the signal); also known as cross correlation. So, there is a **self-correlation** (Self-Correlation) and **cross-correlation** (Cross-Correlation).

Properties of self-correlation and code are shown in the diagram given below where correlation between spreading code 'A' and spreading code 'B' is shown. In this example, the calculated correlation of spreading code 'A' (1010110001101001) and spreading code 'B' (1010100111001001) is given, while performing calculations in below example, the result has come to 6/16.

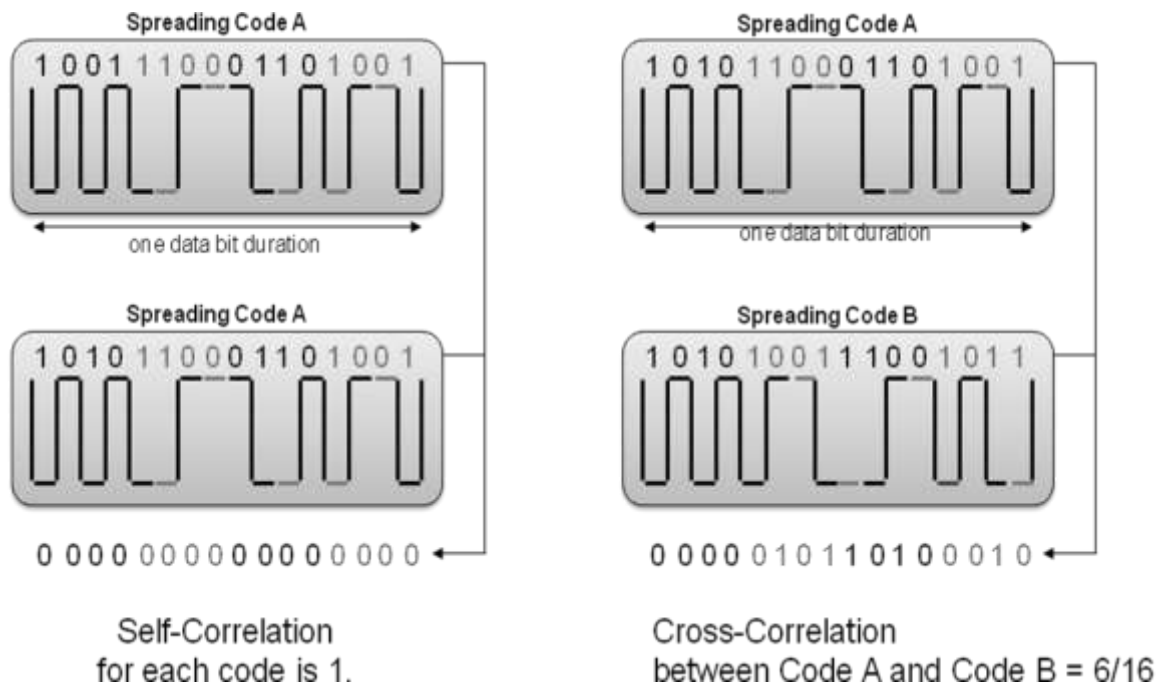

### Preferable Codes

Preferable code is used in CDMA. There are different codes that can be used depending on the type of a system of CDMA. There are two types of system:

1. Synchronous (Synchronous) System and
2. Asynchronous (Asynchronous) System.

In a synchronous system, orthogonal codes (Orthogonal Code) can be used. In asynchronous system for this, such as pseudo-random code (Pseudo-random Noise) or Gold code is used.

In order to minimize mutual interference in DS-CDMA, the spreading codes with less cross-correlation should be chosen.

### Synchronous DS-CDMA

- Orthogonal Codes are appropriate. (Walsh code etc.)

### Asynchronous DS-CDMA

- Pseudo-random Noise (PN) codes/Maximum sequence
- Gold Codes

### Synchronous DS-CDMA

Synchronous CDMA Systems are realized in Point to Multi-point Systems. For example, Forward Link (Base Station to Mobile Station) in Mobile Phone.

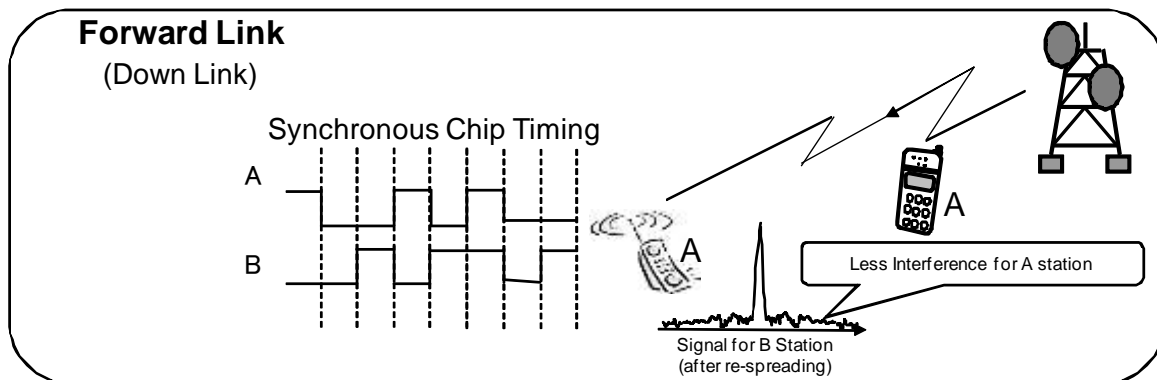

Synchronization system is used in one-to-many (Point to Multipoint) systems. For example, at a given time, in a mobile communication system, a single base station (BTS) can communicate with multiple cell phones (forward link/downlink).

In this system, a transmission signal for all the users can communicate in synchronization. Means, "Synchronization" on this point is a sense that can be sent to align the top of each user signal. In this system, it is possible to use orthogonal codes and it is also possible to reduce mutual interference. And orthogonal codes, it is the sign, such as cross-correlation i.e. 0.

### Asynchronous DS-CDMA

In asynchronous CDMA system, orthogonal codes have bad cross-correlation.

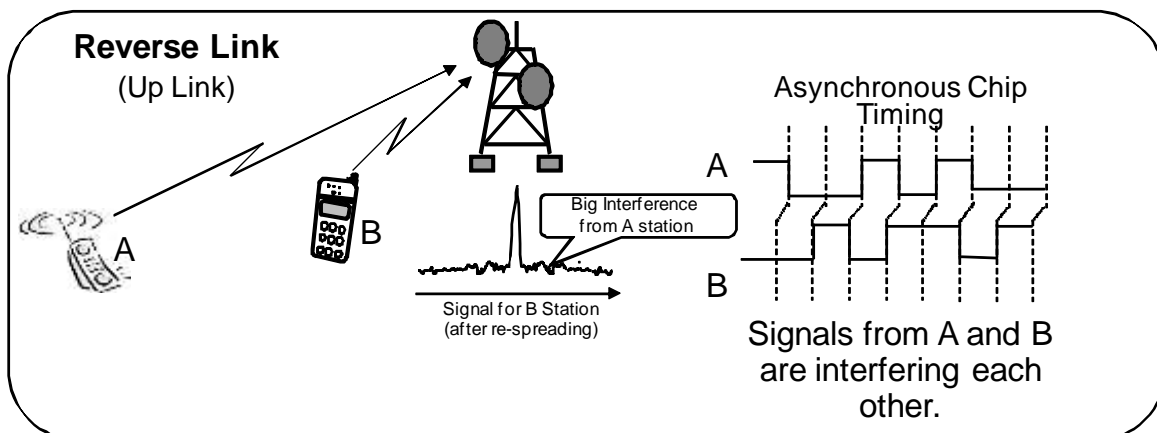

Unlike the signal from the base station, the signal from the mobile station to the base station, becomes the asynchronous system.

In an asynchronous system, somewhat mutual interference increases, but it uses the other codes such as PN code or Gold code.

### Advantages of Spread Spectrum

Since the signal is spread over a wide frequency band, the power spectral density becomes very low, so other communication systems do not suffer from this kind of communication. However, the Gaussian noise increases. Given below is a list of a few major advantages of Spread Spectrum:

- Multipath can be agreed with, as a large number of codes can be generated, allowing a large number of users.
- In spread spectrum, there is no limit of users whereas there is limitations of users in FDMA technology.
- Security: without knowing the spreading code, it is hardly possible to recover the transmitted data.
- Descending rejection: as large bandwidth is used the system; it is less susceptible to deformation.

## PN Sequence

---

The DS-CDMA system uses two types of spreading sequences, i.e., **PN sequences** and **orthogonal codes**. As mentioned above, the PN sequence is generated by the pseudo-random noise generator. It is simply a binary linear feedback shift register, consisting of XOR gates and a shift register. This PN generator has the ability to create a sequence identical for both the transmitter and the receiver, and retaining the desirable properties of the noise randomness bit sequence.

A PN sequence has many features such as having an almost equal number of zeros and ones, very low correlation between shifted versions of the sequence, and very low cross-correlation with other signals such as interference and noise. However, it is able to correlate well with itself and its inverse. Another important aspect is the autocorrelation of the sequence as it determines the ability to synchronize and lock the spreading code for the received signal. This fight effectively effects the multiple interference and improves the SNR. M-sequences, Gold codes, and Kasami sequences are the examples of this class of sequences.

- A Pseudo-random Noise (PN) sequence is a sequence of binary numbers, e.g.  $\pm 1$ , which appears to be random; but it is in fact, perfectly deterministic.
- PN sequences are used for two types of PN spread spectrum techniques:
  1. Direct Signal Spread Spectrum (DS-SS) and
  2. Frequency Hop spread Spectrum (FH-SS).
- If 'u' uses PSK for modulating the PN sequence, it results in DS-SS.
- If 'u' uses FSK for modulating the PN sequence, it results in FH-SS.

## Frequency Hopping Technology

---

Frequency hopping is a spread spectrum in which the propagation takes place by hopping in frequency over a wide band. The precise order in which the break occurs is determined by a hopping table generated by using a pseudo-random code sequence.

Hopping rate is a function of the speed information. The order of frequencies is selected by the receiver and is dictated by the pseudo-random noise sequence. Although the transmission of a frequency hopping signal spectrum is quite different from that of a direct sequence signal, it suffices to note that the data is distributed over a signal band is larger than necessary to carry. In both the cases, the resulting signal will appear as noise and the receiver uses a similar technique, which is used in the transmission to recover the original signal.

# 10. CDMA – Fading

In wireless communications, fading is the deviation of the signal attenuation affecting a certain propagation media. Discoloration may vary with time, the geographical position or frequency of the radio, which is often modeled as a random process. A fading channel is a communication channel experiencing fading.

## Multipath Fading

In wireless systems, fading can be either due to multipath, called as **multipath fading** or due to **shadowing** from obstacles affecting the wave propagation, known as **shadow fading**. Here in this chapter, we will discuss how multipath fading affects the reception of signals in CDMA.

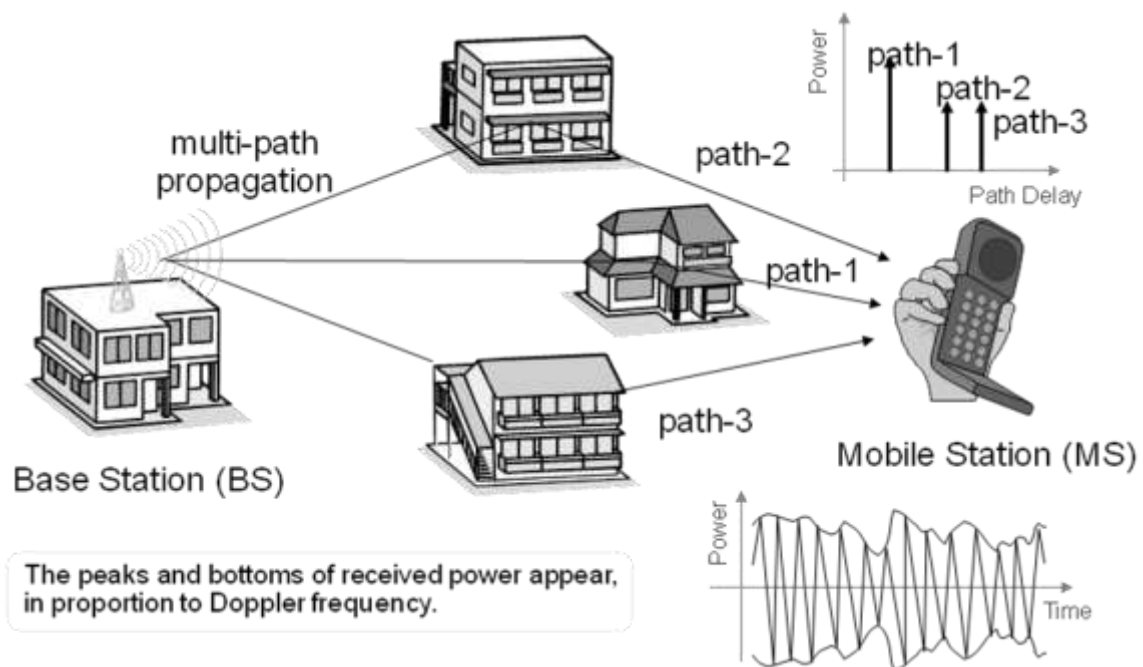

## Fading in CDMA System

CDMA systems use a signal fast chip rate for spreading the spectrum. It has a high time resolution, due to which it receives a different signal from each path separately. The RAKE receiver prevents signal degradation by summing all the signals.

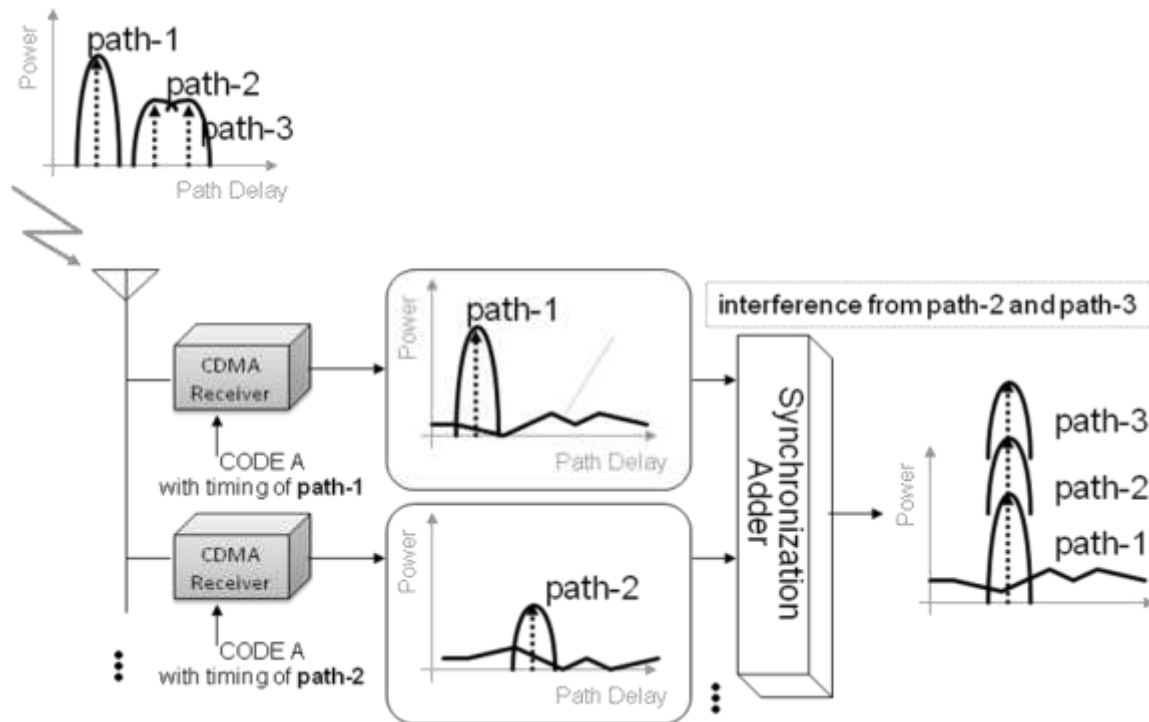

Because CDMA has high time-resolution, different paths delay the CDMA signals, which can be discriminated. Therefore, energy from all paths can be summed by adjusting their phases and path delays. This is a principle of RAKE receiver. By using a RAKE receiver, it is possible to improve the loss of the received signal due to fading. It can ensure a stable communication environment.

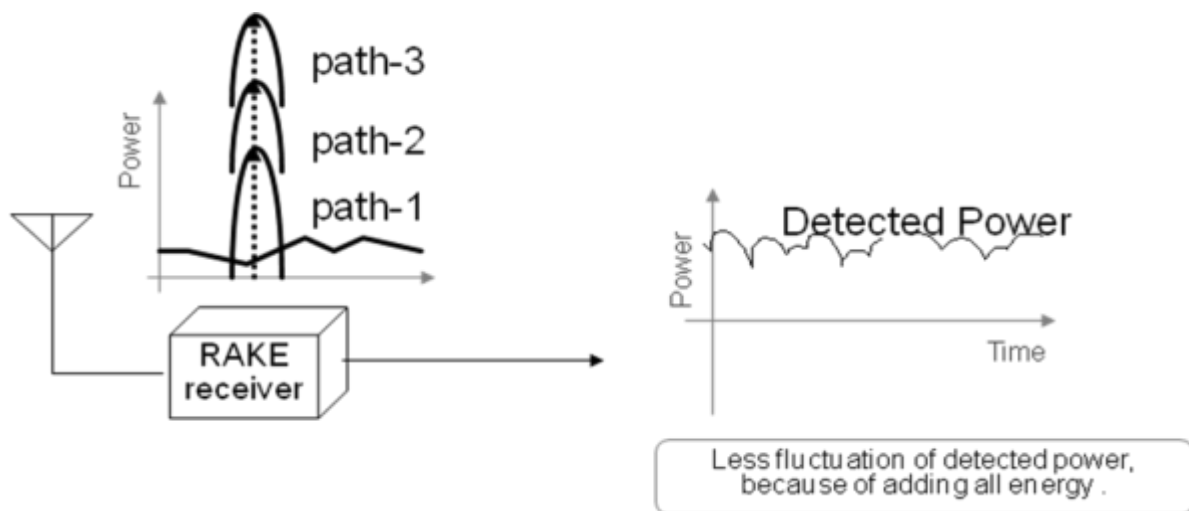

In CDMA systems, multi-path propagation improves the signal quality by using RAKE receiver.



# 11. CDMA – Near-Far Problem

Near-far problem is one of the major problems that hurts mobile communications badly. In a CDMA system, mutual interference will determine the majority of SN ratio of each user.

## How Near-Far Problem Affects Communication?

The following illustration shows how near-far problem affects communication.

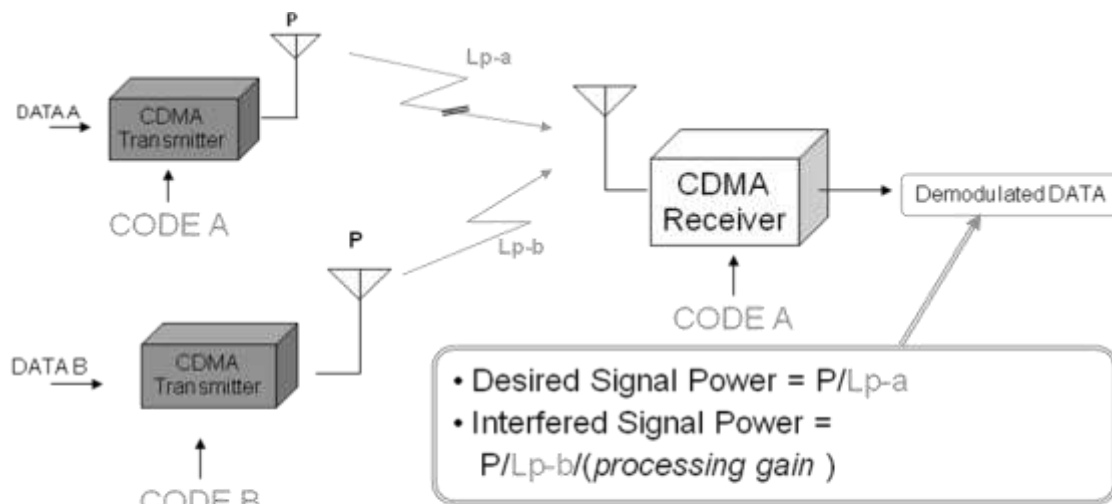

When user B is close to the receiver and user A is far from the receiver,  $L_{p-a}$  could be much bigger than  $L_{p-b}$ . In this case, desired signal power is smaller than the interfered power.

As shown in the illustration, user A is far away from the receiver and user B is close to the receiver, there will be big difference between desired signal power and interfered signal power. Desired signal power will be much higher than the interfered signal power and hence SN ratio of user A will be smaller and communication quality of user A will be severely degraded.

# 12. CDMA – Power Control

In CDMA, since all the mobiles transmit at the same frequency, the internal interference of the network plays a critical role in determining network capacity. Further, each mobile transmitter power must be controlled to limit the interference.

Power control is essentially needed to solve the near-far problem. The main idea to reduce the near-far problem, is to achieve the same power level received by all mobiles to the base station. Each received power must be at least level, so that it allows the link to meet the requirements of the system such that  $E_b/N_0$ . To receive the same power level at the base station, the mobiles those are closer to the base station should transmit less power than the mobiles which are far away from the mobile base station.

In the figure given below, there are two mobile cells A and B. A is closer to the base station and B is far from the base station.  $P_r$  is the minimum signal level for the performance of the required system. Therefore, the mobile B should transmit more power to achieve the same  $P_r$  to the base station ( $P_B > P_A$ ). If there is no power control, in other words, the transmission power are the same from both the mobile cells, the signal received from A is much stronger than the signals received from mobile cell B.

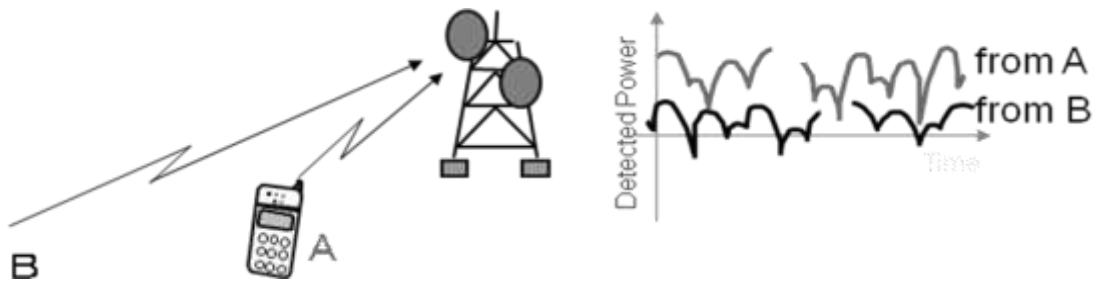

When all mobile stations transmit the signals at the same power (MS), the received levels at the base station are different from each other, which depend on the distances between BS and MSs.

The received level fluctuates quickly due to fading. In order to maintain the received level at BS, a suitable power control technique must be employed in CDMA systems.

We need to control the transmission power of each user. This control is called the **transmission power control** (Control Power). There are two ways to control the transmission power. First is the **open-loop** (Open Loop) control and second is **closed-loop** (Closed Loop) control.

### Open Loop Power Control

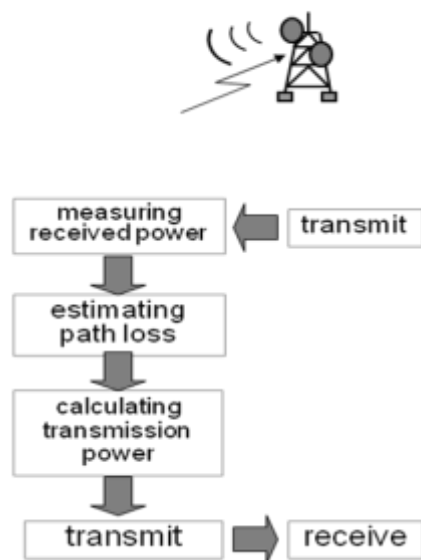

### Closed Loop Power Control

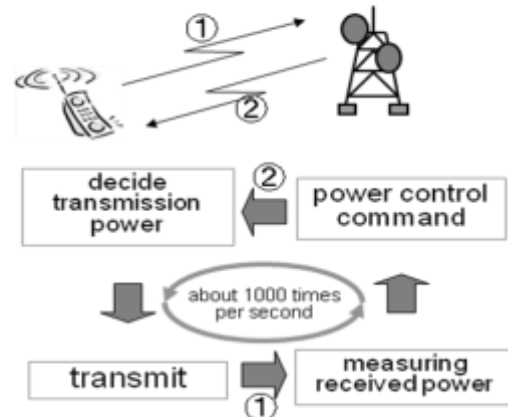

## Reverse Link Power Control

In addition to the near-far effect described above, the immediate problem is to determine the transmit power of the mobile when it first establishes a connection. Until the mobile does not come in contact with the base station, it has no idea of the amount of interference in the system. If it attempts to transmit high power to ensure contact, then it can introduce too much interference. On the other hand, if the mobile transmits less power (not to disturb other mobile connections), the power cannot meet the  $E_b/N_0$  as required.

As specified in the IS-95 standards, mobile acts when it wants to get into the system, it sends a signal called **access**.

In CDMA, each user's transmission power is allocated by the control power to achieve the same power ( $P_r$ ) which is received by the base station/BTS with access probe with low power. The mobile sends its first access probe, then waits for a response from the base station. If it receives no response, then the second access probe is sent with a higher power.

The process is repeated until the base station responds. If the signal answered by the base station is high, then the mobile gets connected with the base station which is closer to the mobile cell with low transmission power. Similarly, if the signal is weak, the mobile knows the path loss is greater and transmits high power.

The process described above is called **open loop power control** since it is controlled only by the mobile itself. Open loop power control starts when the first mobile attempts to communicate with the base station.

This power control is used to compensate for the slow variables shading effects. However, since the rear and forward links are on different frequencies, the estimate transmit power does not give accurate solution for the power control because of the path loss to the front of the base station. This power control fails or too slow for fast Rayleigh fading channels.

The power of closed loop control is used to compensate for the rapid Rayleigh discoloration. This time, the mobile transmit power is controlled by the base station. For this purpose, the base station continuously monitors the reverse link signal quality. If the quality of the connection is low, it tells the mobile to increase its power; and if the quality of the connection is very high, the mobile base station controller reduces its power.

## Forward Link Power Control

Similar, to reverse link power control, forward link power control is also necessary to maintain the forward link quality to a specified level. This time, the mobile monitors the forward link quality and indicates to the base station to turn on or off. This power control has no effect on the near-far problem. All the signals are blurred together at the same level of power when they get to the mobile. In short, there is no near-far problem in the forward link.

## Effect of Power Control

By transmission power control, the user can obtain a constant communication environment regardless of the location. The user who is far from the base station sends a higher transmission power than the user who is nearer to the base station. Also by this transmission power control, you can reduce the effects of fading. This means that the variation of the received power due to fading can be suppressed by the transmission power control.

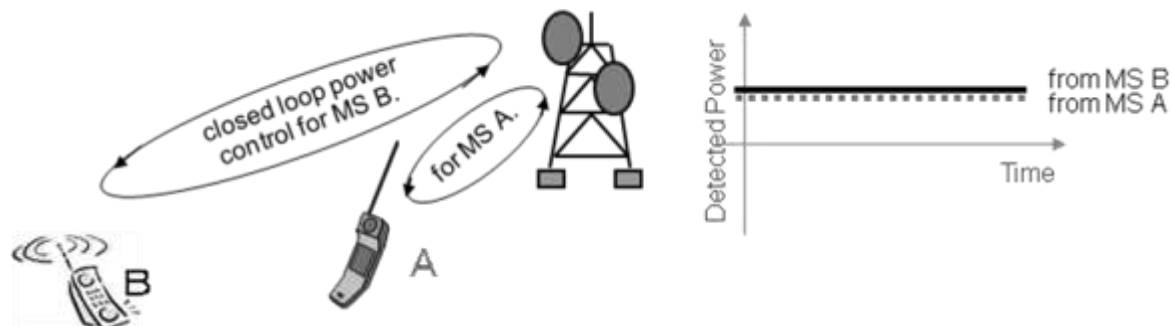

- Power control is capable of compensating the fading fluctuation.
- Received power from all MS are controlled to be equal.
- Near-Far problem is mitigated by the power control.

# 13. CDMA – Frequency Allocation

The major capacity advantage of CDMA is that it reuses the same allocated frequency in every sector of every cell. In IS-136 and analog cellular systems, there is a seven cell repeat factor, with three sectors. This means that only one out of every 21 channels is available to each sector. CDMA is designed to share the same frequency in each sector of each cell. For each user that uses cdma2000 coding rather than IS-95, the system is more efficient.

In FDMA or TDMA, radio resource is allocated not to interfere among neighbor cells:

- Neighbor cells cannot use the same (identical) frequency band (or timeslot).
- The left figure shows the simple cell allocation with seven bands of frequency.

In actual situation, because of complicated radio propagation and irregular cell allocation, it is not easy to allocate frequency (or timeslot) appropriately.

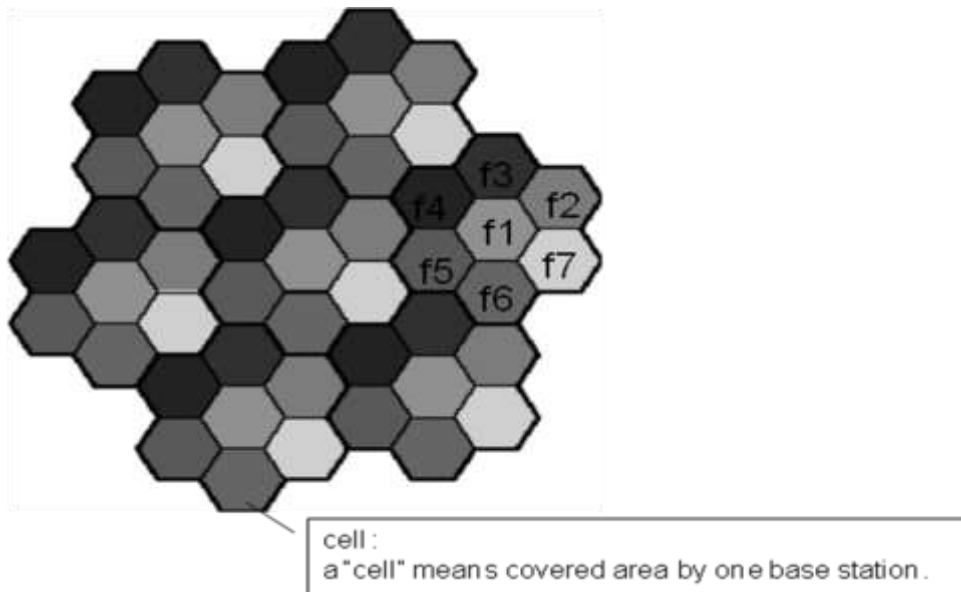

In a CDMA system against this, since all users share the same frequency, the arrangement of the frequency is not an issue. This is the biggest advantage of CDMA technology.

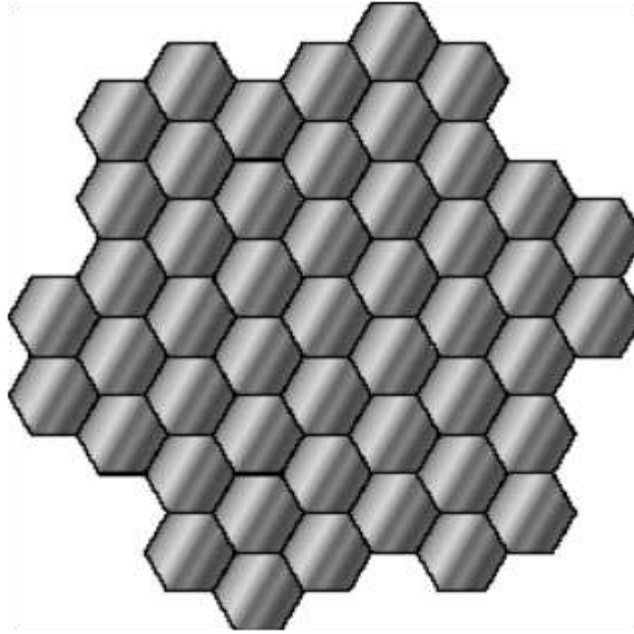

In CDMA, identical radio resource can be used among all cells, because CDMA channels use same frequency simultaneously.

- Frequency allocation in CDMA is not necessary.
- In this sense, CDMA cellular system is easy to design.

# 14. CDMA – Handoff

Whenever a cellular subscriber passes through one base station to another, the network automatically switches to the other respective base station and maintains the coverage responsibility. This behavior called "hand-off" (Handoff) or "hand-over" (Handover).

Whereas in FDMA and TDMA systems, it uses a different frequency to communicate with the base station of that area. It means, there will be a frequency switch from one frequency to another, and during the switching, there will be slightly communication cut, which is called as "**hard handoff**" (Hard Handoff) or "hard handover" (Hard Handover).

## Hard Handoff

---

In FDMA or TDMA cellular system, a new communication can be established after breaking the current communication at the moment of handoff. Communication between MS and BS breaks at the time of switching the frequency or timeslot.

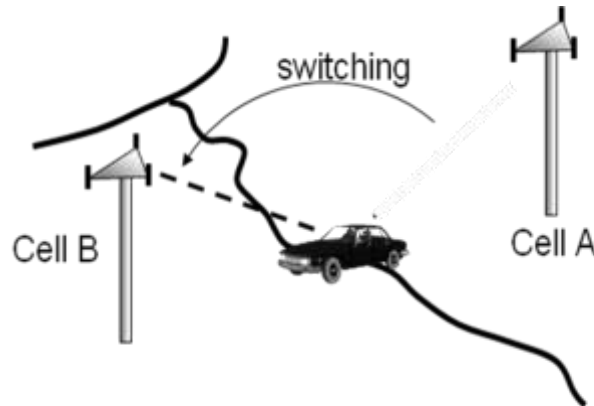

Hard handoff : connect (new cell B) after break (old cell A)

## Soft Handoff

Cellular systems track mobile stations in order to maintain their communication links. When mobile station goes to a neighbor cell, the communication link switches from the current cell to the neighbor cell.

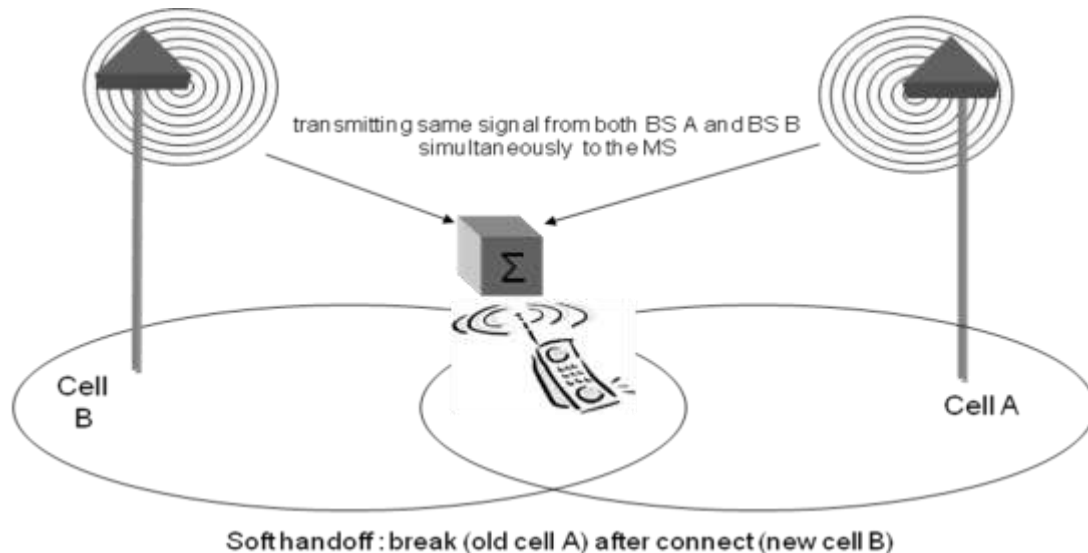

When a mobile enters in a new area (from the base station to another base station), the mobile is the second pilot of sufficient power by sending the message to the strength of the driver to the first base station. The base station notifies the MTSO and then the MTSO requests new **Walsh code assignment** of the second base station.

- The first base station controls with new progressive transfer Walsh assignment MTSO then sends land link to the second base station. Mobile is powered by two base stations and MTSO selects the best quality status for every 20 ms.
- The power goes low at the mobile station by the first BS and mobile sends a pilot strength message then the first BS transmission stops and releases the channel. And, traffic channel continues on the second base station.
- In CDMA cellular system, communication does not break even at the moment doing handoff, because switching frequency or timeslot is not required.

**Note:** A Walsh sequence is a part of Orthogonal Codes, whereas other sequences such as PN, Gold, and Kasami are shift register sequences. In case orthogonal codes are assigned to the users, the output of the correlator in the receiver will be zero except the desired sequence, whereas synchronous direct sequence receiver receives the same code sequence which was transmitted, so there is no time shift between the users.



# 15. CDMA – Interferences

A CDMA signal experiences high interference signals other than the CDMA users. This takes two forms of interference — interference from other users in the same minicell and interference from the adjacent cells. The total interference also includes the background noise and other spurious signals.

CDMA is based on the use of a spread spectrum form of modulation to encode a signal for its transmission and retrieval.

## Noise Sources

---

In the spread spectrum technology, the radio signals are distributed on a single 1.23 MHz wide frequency band. Each subscriber has assigned PN codes. Signals corresponding to the PN codes are decoded and processed. Signals that do not contain the code matches are treated as noise and ignored.

### Signal Processing: Receive

CDMA starts with an encoded narrowband signal; this spreads with the use of the PN codes to a bandwidth of 1.23 MHz.

When the signal is received, it is filtered and processed to recover the desired signal. A correlator eliminates sources of interference because they are uncorrelated with the desired signal treatment. Using this method, the number of CDMA calls can occupy the same frequency spectrum simultaneously.

### Frame Error Rate

The number of transmission errors, measured in terms of frame error rate (FER). It increases with the number of calls. To overcome this problem, the minicell and mobile site can increase the power until either the mobile or the minicell site can power up more further to reduce FER to an acceptable amount. This event provides a soft limit calls from a particular minicell and depends on:

- The noise floor naturally occurring and man-made interference.
- Interference from calls on this minicell.
- Interference from calls on other cells.

### Power per Walsh Code

The power control bit is used during call processing to maintain the relative power of each individual active traffic channel and power up or down to maintain acceptable FER measurements by the mobile on the channel. This power is expressed in terms of digital gain units.

The following actions can be seen in the transmit path: -

- The low bit rate digital voice packet from PSU2 (packet switch unit 2 in the 5ESS switch) is spread by a Walsh code in the minicell.

- The RF transmit carrier frequency is modulated by the spread signal.
- The direct sequence spread spectrum signal is transmitted.

The following actions can be seen in the receive path: -

- The direct sequence spread spectrum signal is received.
- The signal is demodulated by using the RF receive carrier frequency.
- The signal despreads by using the same Walsh code.
- A bit detector restores the decoded signal to a reasonable representation of original speech pattern.

# 16. CDMA – Q & A

## 1. What is CDMA?

CDMA stands for **C**ode **D**ivision **M**ultiple **A**ccess. It is a wireless technology used in transmission of signals from places with high Security and noise reduction. The principle of Spread Spectrum is used to work with CDMA. Spread signal is below the noise level and noise has no effect on the signal. CDMA is not a frequency specific to each user, instead, every channel uses the full available spectrum. Individual conversations are encoded with a pseudo-random digital sequence. A unique code is received by all mobile network users and is allowed continuous network access instead of intermittent or timed access.

## 2. Explain CDMA Development Group (CDG).

CDG is comprised of service providers, infrastructure manufacturers, device vendors, test equipment vendors, application developers, and content providers. Its members jointly define the technical requirements for the development of complementary systems CDMA2000 and 4G and interoperability with other emerging wireless technologies to increase the availability of wireless products and services to consumers and businesses worldwide.

## 3. What is Forward Channels in CDMA?

The forward channel CDMA is the direction of the communication or mobile-to-cell downlink path.

## 4. How many Channels are there in CDMA Forward Channels?

Forward channel consists of four channels which includes:

1. Pilot Channel,
2. Sync Channel,
3. Paging Channel, and
4. Forward Traffic Channels.

## 5. Explain Pilot Channel.

Pilot channel is a reference channel using the mobile station to acquire the time and as a phase reference for coherent demodulation. It is continuously transmitted by each base station on each active CDMA frequency. Each mobile station tracks this signal continuously.

**6. Explain Sync Channel.**

Synchronization channel carries a single repeating message and transmits the synchronization configuration information and the system of the mobile station in the CDMA system.

**7. Explain Paging Channel.**

Paging Channels' main objective is to send out pages, that is, notifications of incoming calls, to the mobile stations. The base station uses these pages to transmit system overhead information and mobile station specific messages.

**8. Explain Forward Traffic Channel.**

Forward Traffic Channels are code channels and used to assign calls, usually voice and signaling traffic to the individual users.

**9. What is Reverse Channels in CDMA?**

The Reverse CDMA channel is the mobile-to-cell direction of the communication or uplink path.

**10. How many Channels are there in CDMA Reverse Channels?**

Reverse channel is consists of two channels which includes:

1. Access Channels and
2. Reverse Traffic Channels.

**11. Explain Access Channels.**

Access channels are used by mobile stations to establish communications with the base station or to answer Paging Channel messages. The access channel is used for short signaling message exchanges such as call-ups, responses to pages, and registrations.

**12. Explain Reverse Traffic Channels.**

Reverse traffic channels are used by individual users in their actual calls to transmit traffic from a single mobile station to one or more base stations.

**13. Explain the CDMA Capacity.**

The factors deciding capacity are:

- Processing Gain,
- Signal to Noise Ratio,
- Voice Activity Factor, and
- Frequency Reuse Efficiency.

Capacity in CDMA is soft, CDMA has all users on each frequency and users are separated by code. This means, CDMA operates in the presence of noise and interference. In addition, neighboring cells use the same frequencies, which means no re-use. So, CDMA capacity calculations should be very simple. No code channels in a cell, multiplied by no cells. But it is not that simple. Although not available code channels are 64, it may not be possible to use a single time, since the CDMA frequency is the same. Flexible capability means that all the code channels can be pursued at a time, but at the expense of quality.

**14. Describe the Centralized Methods in CDMA.**

- The band used in CDMA is 824 MHz to 894 MHz (50 MHz + 20 MHz separation);
- Frequency channel is divided into code channels; and
- 1.25 MHz of FDMA channel is divided into 64 code channels.

**15. Explain Processing Gain in CDMA.**

$$P(\text{gain}) = 10\log(W/R)$$

W is Spread Rate

R is Data Rate

$$\begin{aligned} \text{For CDMA } P(\text{gain}) &= 10\log(1228800/9600) \\ &= 21\text{dB} \end{aligned}$$

$$\begin{aligned} \text{Actual processing gain} &= P(\text{gain}) - \text{SNR} \\ &= 21 - 7 = 14\text{dB} \end{aligned}$$

CDMA uses variable rate coder

The Voice Activity Factor of 0.4 is considered = -4dB.

CDMA has 100% frequency reuse. Use of same frequency in surrounding cells causes some additional interference.

In CDMA, frequency reuse efficiency is 0.67 (70% eff.) = -1.73dB

## 16. What are the CDMA Identities?

Network Identities:-

- SID (System Identity)
- NID (Network Identity)

Mobile Station Identities:-

- ESN (Electronic Serial Number)
- Permuted ESN
- IMSI (International Mobile Station Identity)
- IMSI\_S
- IMSI\_11\_12
- Station Class Mark

## 17. What is ESN (Electronic Serial Number)?

31 bit                      23 bit   24 bit                      17 bit   18 bit                      0 bit

MFR CODE	RESERVED VALUE	SERIAL NUMBER
----------	----------------	---------------

The ESN is a 32-bit binary number that uniquely identifies the mobile station in a CDMA cellular system.

## 18. What is Permuted ESN? Explain.

CDMA is a spread spectrum technique where multiple users to access the system at the same example in a cell, and of course on the same frequency. Therefore, discriminate the users on the reverse link (i.e. information from MS to the base station). It spreads information using codes that are unique to the mobile station in all the CDMA cellular systems. This code has an element that is the ESN. But it doesn't use the ESN in the same format; instead, it uses an ESN swapped.

### 19. What is International Mobile Station Identity (IMSI)?

MCC	MSN	MSIN
	NMSI	
IMSI ≤ 15 digits		

- MCC: Mobile Country Code
- MNC: Mobile Network Code
- MSIN: Mobile Station Identification
- NMSI: National Mobile Station Identity

### 20. What is the Function of IMSI?

The mobile stations are identified by the identity of the international mobile station (IMSI). The IMSI consists of up to 10 to 15 numerical characters (0-9). The first three digits of the IMSI is the country code of the mobile (MCC), the remaining digits are the National NMSI mobile station identity.

The NMSI consists of the mobile network code (MNC) and the mobile station identification number (MSIN). An IMSI is 15 digits in length is called a class 0 IMSI (NMSI is the 12 digits in length). IMSI, which is less than 15 digits in length, is a class called IMSI (NMSI the length is less than 12 counts).

For CDMA operation, the same IMSI may be registered in multiple mobile stations. Individual systems may or may not allow these capabilities. The management of these functions is a function of the base station and the system operator.

### 21. What is FDD and what are the Frequencies it uses?

Frequency Division Duplex is one of the multiple access methods in wireless technology; it uses following frequency bands:

Uplink: 1920 MHz - 1980 MHz and

Downlink: 2110 MHz - 2170 MHz.

### 22. What is TDD and what are the Frequencies it uses?

TDD is Time Division Duplex. A duplex method by which the Uplink and the Downlink transmissions are carried over the same frequency using synchronized time intervals. The carrier uses a 5 MHz band, although there is a low chip rate solution under study by the 3GPP (1.28 Mcps). The available frequency bands for TDD will be 1900-1920 MHz and 2010-2025 MHz.

**23. What is FDMA? Explain.**

**F**requency **D**ivision **M**ultiple **A**ccess (FDMA) is one of the most common analogue multiple access methods. The frequency band is divided into channels of equal bandwidth so that each conversation is carried on a different frequency. Guard bands are used between the adjacent signal spectra to minimize crosstalk between the channels.

**24. What are the Advantages of FDMA?**

In FDMA when the channel is not used, it is the channel bandwidth while rest simply is relatively narrow (30 KHz), known as System narrowband. Little or no equalization is needed. For broadcasting, time symbols are suitable analogue links. Framing for FDMA or synchronization bits are not needed for the tight filter streaming. It is required to minimize the combined interference of FDD.

**25. What are the Disadvantages of FDMA?**

- It does not differ significantly from analog systems; improving the capacity depends on the signal-to-interference reduction, or a signal-to-noise ratio (SNR).
- The maximum flow rate per channel is fixed and small.
- Guard bands lead to a waste of capacity.
- Hardware implies narrowband filters, which cannot be realized in VLSI and therefore increases the cost.

**26. What is TDMA? Explain.**

**T**ime **D**ivision **M**ultiple **A**ccess (TDMA) is a complex technology, because it requires a very accurate synchronization between the transmitter and the receiver. The TDMA is used in digital mobile radio systems. The individual mobile stations are assigned cyclically a frequency for exclusive use for the duration of a time interval.

**27. What are the Advantages of TDMA?**

- It permits flexible rates (i.e., several slots can be assigned to a user, for example, each time interval translates 32Kbps, a user is assigned two 64 Kbps slots per frame).
- It can withstand gusty or variable bit rate traffic. Number of slots allocated to a user can be changed frame by frame (for example, two slots of the frame 1, frame 2 of the three slots, one slot in the frame 3, frame 0 of the notches 4, etc.)
- No guard bands required for the wideband system.
- No narrowband filters required for the wideband system.



**28. What are the Disadvantages of TDMA?**

- The high data rates of broadband systems require complex equalization.
- Due to the burst mode, a large number of additional bits for synchronization and supervision are needed.
- Call time is needed in each slot to accommodate time to inaccuracies due to clock instability.
- Electronics operating at high bit rates increase energy consumption.
- Complex signal processing is required to synchronize within short slot.

**29. What is CDMA? Explain.**

Code Division Multiple Access system is very different from time and frequency multiplexing. In this system, a user has access to the whole bandwidth for the entire duration. The basic principle is that different CDMA codes are used to distinguish between different users. Forms generally used are direct sequence spread spectrum modulation (DS-SS), frequency hopping or mixed CDMA detection (FHSS/JDSS). Here, a signal is generated which extends over a wide bandwidth. A code called spreading code is used to perform this action. Using a group of codes, which are orthogonal to each other, it is possible to select a signal with a given code in the presence of many other signals with different orthogonal codes.

**30. What are the Advantages of CDMA?**

- CDMA has a soft capacity. The greater the number of codes, the more number of users. However, many codes are used S/I drops and the BER (Bit Error Rate) will increase for all users.
- CDMA requires a tight power control as it suffers from near-far effect. In other words, a user near the base station transmits the same power as a user later will drown the latter signal. All signals must have more or less equal power at the receiver.
- Rake receivers can be used to improve signal reception. Delayed versions of time (a chip or later) of the signal (multipath signals) can be collected and used to make decisions at the bit level.
- Flexible transfer may be used. Mobile base stations can switch without changing operator. Two base stations receive mobile signal and the mobile receives from two base stations.
- Transmission Burst - reduces interference.

### 31. What are the Disadvantages of Code Division Multiple Access?

- The code length must be carefully selected. A large code length can induce delay or may cause interference.
- Time synchronization is required.
- Gradual transfer increases the use of radio resources and may reduce capacity.
- As the sum of the power received and transmitted from a base station needs constant tight power control. This can result in several handovers.

### 32. What are the Differences between CDMA and FDMA?

CDMA	FDMA
<p>The same frequency is used by each user.</p> <p>Simultaneous transmission occurs and each narrowband signal is multiplied by spreading the broadband signal, usually called code word.</p> <p>Each user has a separate code pseudo-word that is orthogonal to the other. Only the desired code word is detected by receivers and the other code appears as noise.</p> <p>It is mandatory for the receivers to know about the issuer code word.</p>	<p>When the channel is not used, it is the channel bandwidth while rest simply is relatively narrow (30 KHz), known as <b>System narrowband</b>.</p> <p>Little or no equalization is needed.</p> <p>For broadcasting, time symbols are suitable analogue links.</p> <p>Framing for FDMA or synchronization bits are not needed for the tight filter streaming. It is required to minimize the combined interference of FDD.</p>

### 33. What is Spread Spectrum Technique?

Spread spectrum is a form of wireless communications in which the frequency of the transmitted signal is deliberately varied. This results in a much greater bandwidth than the signal would have, if its frequency were not varied. In other words, the transmitted signal bandwidth is greater than the minimal information bandwidth needed to successfully transmit the signal. Some function other than the information itself is being employed to determine the resultant transmitted bandwidth.

### 34. How many types of Spread Spectrum Techniques are used in CDMA?

Following two types of spread spectrum techniques are used:

1. Direct Sequence and
2. Frequency Hopping.

### 35. What is Frequency Hopping?

Frequency hopping is a spread spectrum in which the propagation takes place by hopping in frequency over a wide band. The precise order in which the break occurs is determined by a hopping table generated by using a pseudo-random code sequence.

### 36. What are the Advantages of Spread Spectrum?

- Since the signal is spread over a wide frequency band, the power spectral density becomes very low, so other communications systems do not suffer from this kind of communication. However, the Gaussian noise increases.
- Multipath can be agreed with, as a large number of codes can be generated, allowing a large number of users.
- The maximum number of users have not limited spectrum or resource, as other access systems such as FDMA, here they have only limited interference.
- Security: without knowing the spreading code, it is almost impossible to recover the transmitted data.
- Descending rejection: as large bandwidth is used the system, it is less susceptible to deformation.

### 37. What is PN Sequence in CDMA? Explain.

The DS-CDMA system uses two types of spreading sequences — PN sequences and orthogonal codes. The PN sequence is generated by the pseudo-random noise generator which is simply a binary linear feedback shift register, consisting of XOR gates and a shift register. This PN generator has the ability to create a sequence identical for both the transmitter and the receiver, and while retaining the desirable properties of the noise randomness bit sequence.

### 38. What is Multi-path Fading? Explain.

In wireless communications, fading is the deviation of the signal attenuation affecting a certain propagation media. Discoloration may vary with time, the geographical position or frequency of the radio, which is often modeled as a random process. A fading channel is a communication channel experiencing fading. In wireless systems, fading can be due to multipath, called multi-path fading.

### 39. What is Rake Receiver?

CDMA system uses a signal fast chip rate for spreading spectrum and it has a high time resolution. For this reason, CDMA is able to recognize by decomposing each of the path to reach with the time difference. From this, it receives a different paths of signal each one separately, by summing later, it can prevent signal degradation. This is called as the RAKE receiver.

**40. What is Walsh Code? Explain.**

Walsh Codes are most commonly used in CDMA applications orthogonal codes. These codes correspond to lines of a special square matrix called the Hadamard matrix. For a set of Walsh codes of length  $N$ , it consists of  $n$  lines to form a square matrix of  $n \times n$  Walsh code. The IS-95 system uses 64 Walsh function matrix 64. The first line of this matrix contains a string of all zeros with each of the following lines containing different combinations of bit 0 and 1. Each line is orthogonal and equal representation for binary bits. When implemented with the CDMA system, each mobile user uses one of the 64 sequences of rows in the matrix as a spreading code, providing zero cross-correlation among all the other users.

**41. What is Soft Handover/Handoff?**

Cellular system tracks mobile stations in order to maintain their communication links. The mobile station goes to neighbor cell and communication link switches from current cell to the neighbor cell which is called as soft handover.

- Soft handoff is a feature in which a cellular phone is simultaneously connected to two or more cellular phones during a single call.
- It is the overlapping of repeater coverage ones, which enables every cell phone set is always well within the range of a specific repeater.
- More than one repeater can send and receive signals to transmit signals to and from mobiles.
- All repeaters are used with the same frequency channel for each mobile phone set.
- Practically no dead zones and as result, the connections seldom interrupted or dropped.

**42. What is Hard Handover? Explain.**

In FDMA or TDMA cellular system, new communication establishes after breaking current communication at the moment doing handoff. Communication between MS and BS breaks at the moment switching frequency or timeslot which is known as hard handover.

**43. What is Power Control?**

Power control is the intelligent selection of transmit power in a communication system for achieving best performance within the system. The performance depends on context and there are chances to include optimizing metrics like link data rate, network capacity, geographic coverage, and range. A higher transmit power translates into a higher signal power at the receiver.

**44. What is Reverse Link Power Control? Explain.**

The power of closed loop control is used to compensate for the rapid Rayleigh discoloration. This time, the mobile transmitted power is controlled by the base station. For this purpose, the base station continuously monitors the reverse link signal quality.

If the quality of the connection is poor then the base station increases the power. Similarly, if the quality of the link is very high then the mobile base station controller reduces the power. This is called as reverse link power control.

#### **45. What is Forward Link Power Control? Explain.**

Similar to reverse link power control, forward link power control is also necessary to maintain the forward link quality to a specified level. This time, the mobile monitors the forward link quality and indicates to the base station to turn on or off, this power control has no effect on the near-far problem because all the signals are blurred together the same level of power when they get to the mobile. In short, there is no near-far problem in the forward link.

#### **46. Explain the Effects of Power Control.**

- Power control is capable of compensating the fading fluctuation.
- Received power from all MS are controlled to be equal.
- Near-Far problem is mitigated by the power control.

#### **47. Explain the Frequency Allocation Concept.**

In FDMA or TDMA, radio resource is allocated not to interfere among neighbor cells:

- Neighbor cells cannot use the same (identical) frequency band (or timeslot).
- The left figure shows the simple cell allocation with seven bands of frequency.
- In actual situation, because of complicated radio propagation and irregular cell allocation, it is not easy to allocate frequency (or timeslot) appropriately.

CDMA system is against this, since all users share the same frequency, the arrangement of the frequency is not an issue. This is in designing the system, which will be a very big advantage.

#### **48. What are the Interferences in CDMA?**

There are four main interferences in CDMA as given below:

1. Noise sources,
2. Signal processing,
3. Frame error rate, and
4. Power per Walsh code.

**49. Explain the CDMA Interference "Frame Error Rate."**

The number of transmission errors, measured in terms of a frame error rate (FER). It increases with the number of calls. To overcome this problem, the minicell and mobile site can increase the power until either the mobile or the minicell site can power up more further to reduce FER to an acceptable amount. This event provides a soft limit calls from a particular minicell.